



Operating Manual for

PVS Series Power Supply

**This manual covers
1200 watt models:**

7.5-140	100-12
12-100	150-8
20-60	300-4
40-30	600-2
60-20	

PVS シリーズ 取扱説明書 正誤表

本取扱説明書の記述を以下のように変更いたします。お手数ですが訂正してご使用ください。

1-7,1-8 ページ脚注の 2.

誤

最小出力電流はゼロ出力設定において各モデル定格電流の0.5%未満です。ただし、定格の10%以上の負荷が接続されている場合。

正

最小出力電流はゼロ出力設定において各モデル定格電流の0.2%未満です。ただし、定格負荷の抵抗 ($R=V_{max}/I_{max}$)が接続されている場合。

PVS Series Operation Manual Errata

Please make the following changes to the text in this document.

Pages 1-7 and 1-8, 2 of footnote

Wrong

Minimum output current is <0.5% of rated current at zero output setting when measured at minimum 10% of full power load.

Right

Minimum output current is <0.2% of rated current at zero output setting when measured at rated load resistor ($R=V_{max}/I_{max}$).

WARRANTY

This unit is guaranteed for one (1) year from the date of delivery against defects in material and workmanship. This does not apply to products damaged through accident, abuse, misuse, or unauthorized repair. The manufacturer shall not be liable for any special or consequential damage of any nature. The manufacturer will repair or replace the non-conforming product or issue credit, at its option, provided the manufacturer's inspection establishes the existence of a defect. Packing, freight, insurance and other charges incurred in returning the defective products to the manufacturer will be paid by the purchaser. The manufacturer will pay return freight if the repaired unit is deemed to be under warranty. If any questions arise concerning the warranty, check with the manufacturer prior to taking any action.

When requesting information, assistance, or authorization, please state the serial number of the unit, available from the label on the unit. Give a brief description of the problem with the unit. For information about packaging for shipping, see Section 2.3.3.

GENERAL WARNINGS AND CAUTIONS



HIGH ENERGY AND HIGH VOLTAGE WARNING

Exercise caution when operating a power supply. High energy levels can be stored at the output voltage terminals on a power supply in normal operation. In addition, potentially lethal voltages exist in the power circuit and on the output and sense connectors of a power supply with a rated output greater than 40 V. Filter capacitors store potentially dangerous energy for some time after power is removed.



WARNING — SURFACE MAY BE HOT

During normal operation at 50 °C ambient temperature, the power supply's cover temperature may exceed 75 °C.

OPERATING AND SERVICE PRECAUTIONS

Operate the power supply in an environment free of flammable gases or fumes. To ensure that the power supply's safety features are not compromised, use the power supply as specified in this manual and do not use substitute parts or make any unauthorized modifications. Contact the service technician for service and repair help. Repairs must be made by experienced service technicians only.

Confidential Information

The information contained in this document is confidential and is the exclusive property of the manufacturer. It may not be disclosed to any person without the express written consent of the manufacturer.



SAFETY PRECAUTIONS

The following safety precautions must be observed to avoid fire hazard, electrical shock, accidents, and other failures. Keep them in mind and make sure that all of them are observed properly. Kikusui assumes no liability against any damages or problems resulting from negligence of the precautions.

Users

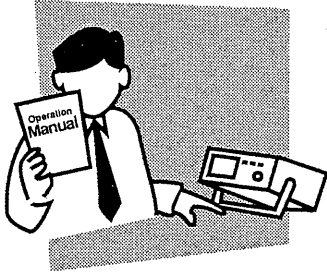

- This product must be used only by qualified personnel who understand the contents of this operating manual.
- If it is handled by unqualified personnel, personal injury may result. Be sure to handle it under supervision of qualified personnel (those who have electrical knowledge.)

Purposes of Use

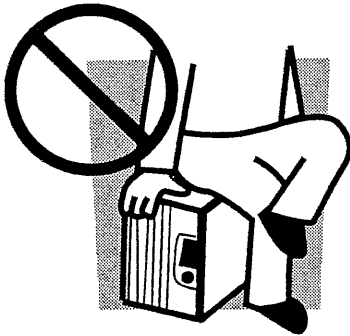

- If the product is to be used for purposes not described in this manual, contact your Kikusui agent in advance.

Input Power

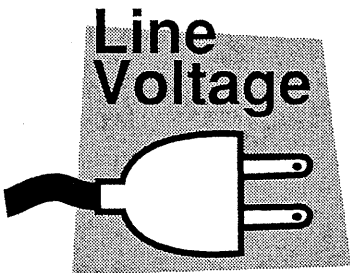

- Use the product with the specified input power voltage.
- For applying power, use the AC power cable provided. The shape of the plug differs according to the power voltage and local area standards. Use the cable which is suitable for the line voltage used.

Fuse

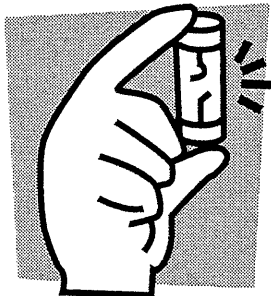

- With products with a fuse holder on the exterior surface, the fuse can be replaced with a new one. When replacing a fuse, use the one which has appropriate shape, ratings, and specifications.

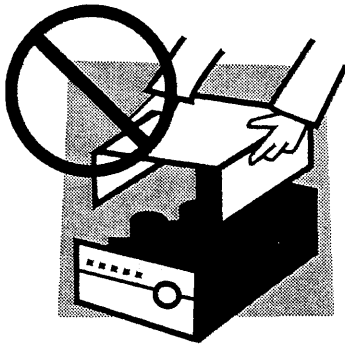

Cover

- There are parts inside the product which may cause physical hazards. Do not remove the external cover. If the cover must be removed, contact your Kikusui agent in advance.

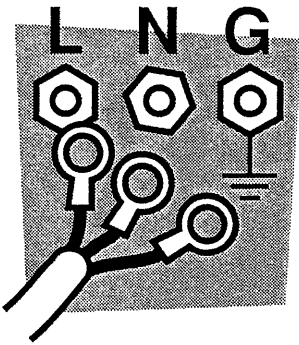

Installation

- When installing products be sure to observe Section 2. Installation described in this manual.
- To avoid electrical shock, connect the protective ground terminal to electrical ground (safety ground).
- When applying power to the products from a switchboard, be sure that work is performed by a qualified and licensed electrician or is conducted under the direction of such a person.
- Be sure to use the AC power cable provided. Consult your Kikusui agent if a cable other than the one included is to be used for some reason.



Relocation

- Turn off the power switch and then disconnect all cables when relocating the product.
- Use two or more persons when relocating a product which weighs more than 44 lb. (20 kg). The weight of the products can be found on the rear panel of the product and/or in this operation manual.
- Use extra precautions, such as using more people, when relocating into or out of present locations including inclines or steps. Also handle carefully when relocating tall products as they can fall over easily.
- Be sure that the operating manual is included when the product is relocated.

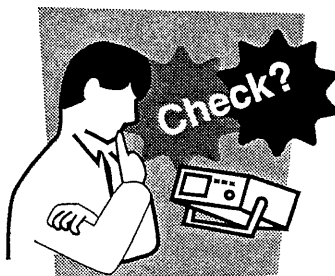

Operation

- Check that the AC input voltage setting and the fuse rating are as specified and that there is no abnormality on the surface of the AC power cable. Be sure to unplug the AC power cable or stop applying power before checking.
- If any abnormality or failure is detected in the products, stop using it immediately. Unplug the AC power cable or disconnect the AC power cable from the switchboard. Be careful not to allow the product to be used before it is completely repaired.
- For output wiring or load cables, use connection cables with larger current capacity.
- Do not disassemble or modify the product. If it must be modified, contact your Kikusui agent.

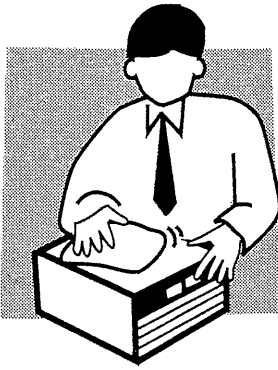

Maintenance and Checking

- To avoid electrical shock, be absolutely sure to unplug the AC power cable or stop applying power before performing maintenance or checking.
- Do not remove the cover when performing maintenance or checking. If the cover must be removed, contact your Kikusui agent in advance.
- To maintain performance and safe operation of the product, it is recommended that periodic checking, cleaning, and calibration be performed.



Service

- Internal service is to be done by Kikusui service engineers. If the product must be adjusted or repaired, contact your Kikusui agent.

ABOUT THIS MANUAL

This Operating Manual contains user information for the PVS Series of variable DC output power supplies, available in several voltage models at 1200 watts. It provides information about features and specifications, installation procedures, and basic functions testing, as well as operating procedures for using both front panel control and remote analog programming functions.

Who Should Use This Manual

This manual is designed for the user who is familiar with basic electrical laws especially as they apply to the operation of power supplies. This implies a recognition of Constant Voltage and Constant Current operating modes and the control of input and output power, as well as the observance of safe techniques while making supply or pin connections and any changes in switch settings.







Section 1. Features and Specifications	Describes the power supply and lists its features and specifications.
Section 2. Installation	Goes through basic setup procedures. Describes inspection, cleaning, shipping, and storage procedures. Includes AC input connection, basic functions testing, and load and sense lines connections.
Section 3. Local Operation	Provides procedures for local (front panel) operation. Includes procedures for using over voltage protection, shutdown function, multiple supplies, and over heat protection.
Section 4. Remote Operation	Covers remote analog programming operation and remote monitoring of output voltage and current.
Appendix A. Procedures for Remote Programming	Provides functional procedures for remote programming using external resistors and external voltage sources.

Manual Revisions

The current release of this manual is listed below. Insert pages may update already printed manuals. Insert material incorporated into a reprinted manual may be identified with a change bar in the page margin.

Release 1.0 (2000-04-26)

Power Supply Safety Markings

	Alternating Current
	Earth (Ground) Terminal
	Protective Conductor Terminal
	On (Supply)
	Off (Supply)
	Caution (Hot Surface)
	Caution (Check manual for additional information.)

Warnings, Cautions, and Notes

Warnings, cautions, and notes are defined and formatted in this manual as presented below.

WARNING

Describes a potential hazard which could result in injury or death, or, a procedure which, if not performed correctly, could result in injury or death.

CAUTION

Describes a procedure which, if not performed correctly, could result in damage to data, equipment, or systems.

Note: Describes additional operating information which may affect the performance of the equipment.

CONTENTS

Safety Precautions..... i
 About This Manualiv
 Contents vi
 List of Figuresviii
 List of Tablesix

1. FEATURES AND SPECIFICATIONS

1.1 Description 1-1
 1.2 Features and Options 1-1
 1.3 Front Panel Controls..... 1-2
 1.4 Rear Panel Connectors and Switch 1-3
 1.4.1 Rear Panel SW1 Switch..... 1-4
 1.4.2 Rear Panel J2 Connector 1-5
 1.5 Specifications 1-7
 1.5.1 Electrical Specifications 1-7
 1.5.2 Additional Specifications 1-9
 1.5.3 Input Conditions 1-9
 1.5.4 Additional Characteristics 1-10
 1.5.5 Remote Programming and Monitoring..... 1-10
 1.5.6 Environmental Specification 1-10
 1.5.7 Mechanical Specification 1-10
 1.5.8 Insulation Resistances and Withstanding Voltages..... 1-12

2. INSTALLATION

2.1 Introduction 2-1
 2.2 Basic Setup Procedure..... 2-1
 2.3 Inspection, Cleaning, and Packaging 2-1
 2.3.1 Initial Inspection..... 2-1
 2.3.2 Periodic Cleaning 2-1
 2.3.3 Packaging for Shipping or Storage..... 2-2
 2.4 Location, Mounting, and Ventilation 2-2
 2.4.1 Rack Mounting 2-2
 2.4.2 Ventilation 2-3
 2.5 AC Input Power..... 2-3
 2.5.1 AC Input Connector and Voltage Selection 2-4
 2.5.2 AC Input Cord 2-4
 2.5.3 AC Input Wire Connection..... 2-5
 2.6 Functional Tests 2-6
 2.6.1 Equipment Required..... 2-6
 2.6.2 Power-on Check 2-6
 2.6.3 Voltage Mode Operation Check..... 2-6
 2.6.4 Current Mode Operation Check 2-7
 2.6.5 Front Panel Function Checks..... 2-7
 2.7 Load Connection 2-8
 2.7.1 Load Wiring..... 2-8
 2.7.2 Making Load Connections 2-9
 2.7.3 Inductive Loads 2-12
 2.7.4 Connecting Single Loads..... 2-13
 2.7.5 Connecting Multiple Loads 2-13
 2.8 Local and Remote Sensing 2-15
 2.8.1 Sense Wiring 2-15
 2.8.2 Local Sensing 2-15
 2.8.3 Using Remote Sensing 2-16

3. LOCAL OPERATION

3.1	Introduction	3-1
3.2	Standard Operation.....	3-1
3.2.1	Operating Modes and Automatic Crossover	3-1
3.2.2	Shipped Configuration (Local Control Mode)	3-2
3.2.3	Setting Output Voltage and Current Limit	3-3
3.3	Using Over Voltage Protection (OVP).....	3-4
3.3.1	Front Panel OVP Operation.....	3-4
3.3.2	Resetting the OVP Circuit.....	3-4
3.4	Using the Shutdown Function	3-5
3.4.1	STANDBY Switch	3-5
3.4.2	Controlling the Shutdown Function via the J2 Connector	3-5
3.5	Using Multiple Supplies.....	3-6
3.5.1	Configuring Multiple Supplies for Series Operation.....	3-6
3.5.2	Configuring Multiple Supplies for Parallel Operation	3-7
3.5.3	Configuring Multiple Supplies for Split Supply Operation	3-8
3.6	Over Heat Protection (OHP)	3-9
3.7	User Diagnostics.....	3-10
3.7.1	Emergency Shutdown.....	3-10
3.7.2	Unusual or Erratic Operation.....	3-10
3.7.3	Troubleshooting for Operators	3-11

4. REMOTE OPERATION

4.1	Introduction	4-1
4.2	Remote Analog Programming of Output Voltage and Current Limit.....	4-1
4.2.1	Remote Programming Options	4-1
4.2.2	Remote Analog Programming Procedure.....	4-2
4.3	Remote Monitoring of Output Voltage and Current	4-4
4.3.1	Readback Signals.....	4-4

APPENDIX A. PROCEDURES FOR REMOTE PROGRAMMING

A.1	Remote Programming with External Resistance	A-1
A.1.1	Remote Output Voltage Control with External Resistance.....	A-1
A.1.2	Remote Output Current Control With External Resistance	A-2
A.2	Remote Programming with External Voltage Sources	A-3
A.2.1	Remote Output Voltage Control with External Voltage Sources.....	A-3
A.2.2	Remote Output Current Control With External Voltage Sources	A-4

LIST OF FIGURES

Figure 1.3-1	Power Supply Front Panel.....	1-2
Figure 1.4-1	Power Supply Rear Panel.....	1-3
Figure 1.4-2	Programming and Monitoring SW1 Switch.....	1-4
Figure 1.4-3	Programming and Monitoring J2 Connector.....	1-5
Figure 1.5-1	Typical Input Current Characteristics, 85-130 Vac Range	1-9
Figure 1.5-2	Typical Input Current Characteristics, 190-264 Vac Range	1-9
Figure 1.5-3	Dimensional Drawings.....	1-12
Figure 2.3-1	Shipping or Storage Carton Label.....	2-2
Figure 2.5-1	AC Input Cover and Strain Relief.....	2-5
Figure 2.7-1	Maximum Load Wire Length for 1 V Line Drop	2-9
Figure 2.7-2	Bus Bar Shield.....	2-10
Figure 2.7-3	Typical Load Connection Hardware	2-10
Figure 2.7-4	Output Voltage Connector with Shield	2-11
Figure 2.7-5	Inductive Load	2-12
Figure 2.7-6	Inductive Load with Resistor	2-12
Figure 2.7-7	Single Load with Local Sensing (Default).....	2-13
Figure 2.7-8	Single Load with Remote Sensing	2-13
Figure 2.7-9	Multiple Loads with Local Sensing	2-14
Figure 2.7-10	Multiple Loads with Remote Sensing	2-14
Figure 2.8-1	J10 Sense Connector	2-15
Figure 2.8-2	Connecting Remote Sense Lines.....	2-17
Figure 3.2-1	Operating Modes.....	3-1
Figure 3.5-1	Series Operation of Multiple Supplies	3-7
Figure 3.5-2	Parallel Operation of Multiple Supplies.....	3-7
Figure 3.5-3	Split Supply Operation of Multiple Supplies (Two Positive Voltages).....	3-8
Figure 3.5-4	Split-Supply Operation of Multiple Supplies (Positive-negative Supply).....	3-9
Figure 4.2-1	Connecting Programming Sources to J2 Connector	4-3
Figure A-1	Remote Output Voltage Control with External Resistance	A-1
Figure A-2	Remote Output Current Control With External Resistance	A-2
Figure A-3	Remote Output Voltage Control with External Voltage Sources	A-3
Figure A-4	Remote Output Current Control With External Voltage Sources.....	A-4

LIST OF TABLES

Table 1.1-1	Available Voltage and Current Ranges.....	1-1
Table 1.4-1	Rear Panel SW1 Switch Assignments (Factory Defaults Underlined).....	1-4
Table 1.4-2	Rear Panel J2 Connector Terminals and Functions	1-5
Table 1.5-1	Electrical Specifications for 7.5 V to 60 V Models	1-7
Table 1.5-2	Electrical Specifications for 100 V to 600 V Models	1-8
Table 2.2-1	Basic Setup Procedure.....	2-1
Table 2.5-1	Operational AC Input Voltage Ranges and Frequency	2-4
Table 2.5-2	AC Wire Specification	2-4
Table 2.7-1	Current Carrying Capacity for Load Wiring	2-8
Table 2.8-1	Rear Panel J10 Sense Connector Terminals and Functions	2-15
Table 3.2-1	Shipped Configuration (Local Control Mode).....	3-2
Table 3.4-1	Switch Settings for Shutdown Circuit Logic	3-5
Table 3.6-1	Switch Settings for Over Heat Recovery Options.....	3-9
Table 3.7-1	User Diagnostics	3-11
Table 4.2-1	Remote Programming Options.....	4-1
Table 4.2-2	Power Supply Settings for Different Programming Sources	4-3
Table 4.3-1	Power Supply Settings for Remote Monitoring of Readback Signals	4-4

1. FEATURES AND SPECIFICATIONS

1.1 Description

This series of power supplies provides low noise, precisely regulated, variable DC output at 1200 watts of output power. Over voltage protection and thermal shutdown are standard. Front panel controls and indicators are extensive. Select from the following remote control choices: standard analog programming and optional GPIB programming. Remote monitoring of output voltage and current is a standard feature. Use this power supply either on your bench or in a standard 19" (483 mm) rack: the power supply occupies only 1.75" (1 U) of vertical rack space. Designed for continuous use in standalone or systems applications, this power supply is typically used to power DC equipment, control magnets, or burn in components. See Table 1.1-1 for the list of available models.

Table 1.1-1 Available Voltage and Current Ranges

Model	Voltage Range	Current Range
7.5-140	0-7.5 V	0-140 A
12-100	0-12 V	0-100 A
20-60	0-20 V	0-60 A
40-30	0-40 V	0-30 A
60-20	0-60 V	0-20 A
100-12	0-100 V	0-12 A
150-8	0-150 V	0-8 A
300-4	0-300 V	0-4 A
600-2	0-600 V	0-2 A

1.2 Features and Options

- Simultaneous digital display of both voltage and current.
- Ten-turn front panel voltage and current controls for high resolution setting of the output voltage and current from zero to the rated output.
- Automatic mode crossover into current or voltage mode.
- Front panel push button control of output standby mode and preview of voltage, current, or over voltage protection (OVP) setpoints. Front panel light emitting diode (LED) indicators for voltage and current mode operation, OVP, remote programming mode, and shutdown. Front panel control of OVP.
- Multiple units can be connected in parallel or series to provide increased current or voltage.
- Thermal shutdown, latching or auto reset.
- Remote analog voltage and current limit programming with selectable programming ranges.
- External monitor signals for output voltage and current.
- Optional internal GPIB control for remote digital programming and readback capability from a computer.
- Rack mount brackets at the front panel are standard.

1.3 Front Panel Controls

See Figure 1.3-1 to review the controls, LEDs, and meters located on the power supply's front panel. Check the following sections for additional descriptions of front panel controls and functions.

- Section 1.5.7 Mechanical Specification
- Section 2.6 Functional Tests
- Section 3. Local Operation

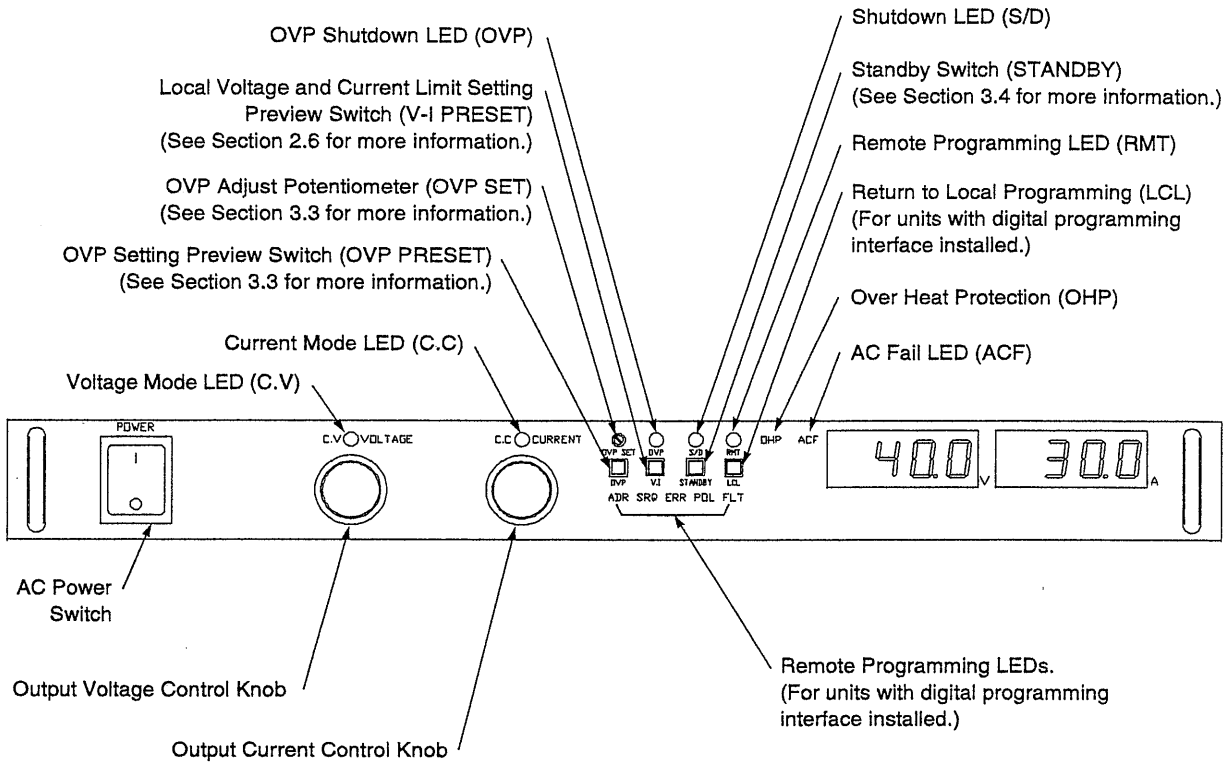

Figure 1.3-1 Power Supply Front Panel

1.4 Rear Panel Connectors and Switch

Use the rear panel SW1 Programming, Monitoring, and Shutdown Select switch and the rear panel J2 Programming and Monitoring connector to choose among several remote programming and monitoring options. See Figure 1.4-1 for the switches and connectors available at the rear panel. See Section 1.4.1 and Section 1.4.2 for a list of switches and connector functions, and procedures for using them.

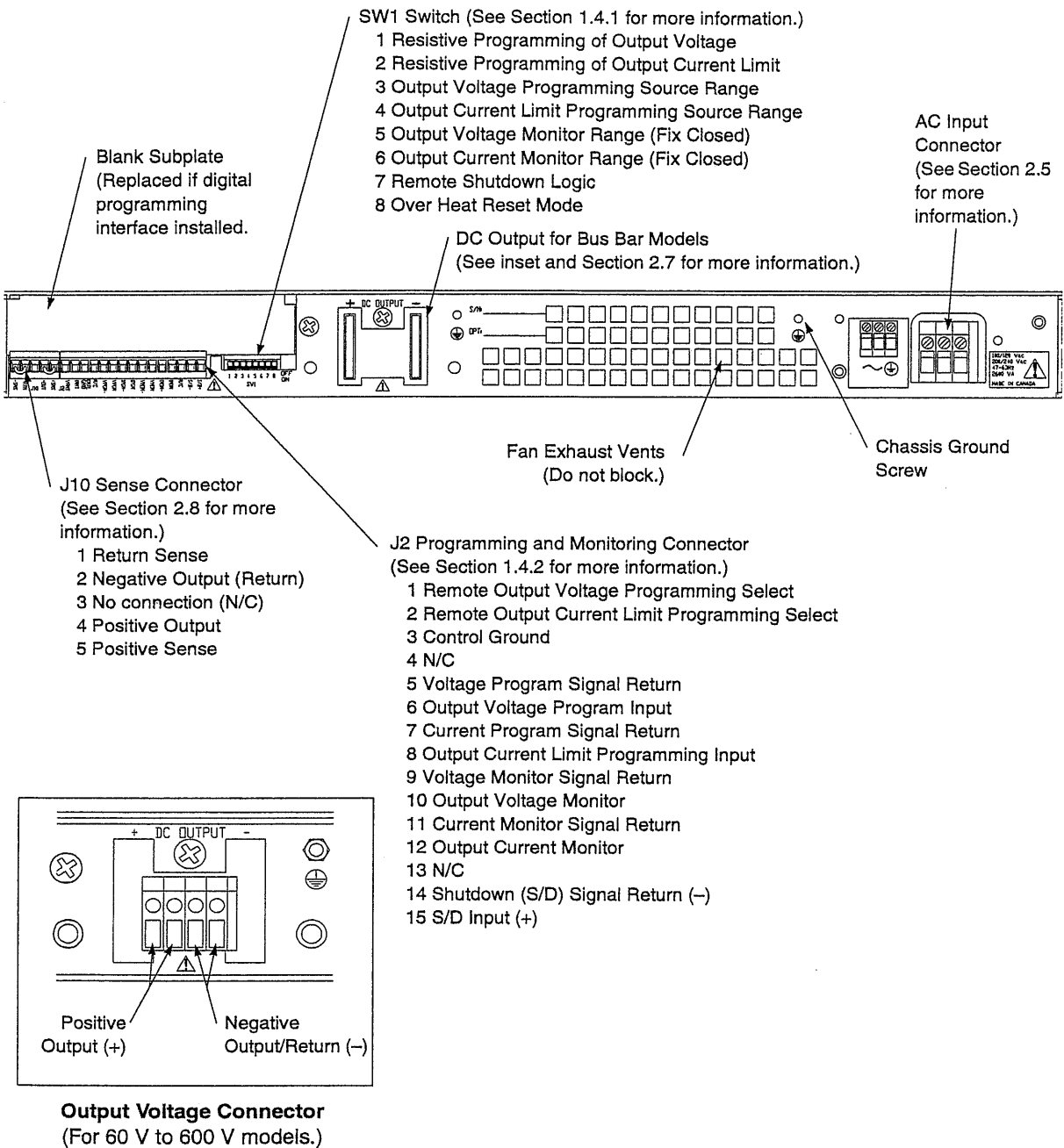

Figure 1.4-1 Power Supply Rear Panel
(Low voltage (7.5 V to 40 V) model shown.)

1.4.1 Rear Panel SW1 Switch

The SW1 Programming, Monitoring, and Shutdown Select switch is an 8-position piano DIP switch located on the power supply's rear panel. See Figure 1.4-2. The SW1 switch enables you to choose:

- Resistive programming of output voltage or current limit
- Output voltage and current limit programming scales
- Output voltage and current monitor setting
- Remote shutdown circuit logic
- Over heat shutdown mode

- 1 Resistive Programming of Output Voltage
- 2 Resistive Programming of Output Current
- 3 Selects Output Voltage Programming Source Range
- 4 Selects Output Current Limit Programming Source Range
- 5 Selects Output Voltage Monitor Range (Fix Closed)
- 6 Selects Output Current Monitor Range (Fix Closed)
- 7 Selects Remote Shutdown Logic
- 8 Selects Over Heat Shutdown Reset Mode

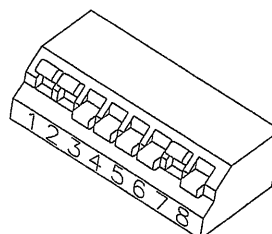

Figure 1.4-2 Programming and Monitoring SW1 Switch
(Switch is shown in factory default configuration.)

Table 1.4-1 shows the functions assigned to each SW1 switch.

Table 1.4-1 Rear Panel SW1 Switch Assignments (Factory Defaults Underlined)

Switch	Function	Open	Closed
SW1-1	1 mA current source for resistive programming of output voltage	<u>Voltage source programming</u>	Resistive programming (0-5 k, 0-10 k)
SW1-2	1 mA current source for resistive programming of output current limit	<u>Voltage source programming</u>	Resistive programming (0-5 k, 0-10 k)
SW1-3	Output voltage programming source range select	0-5 V (0-5 k)	<u>0-10 V</u> (0-10 k)
SW1-4	Output current limit programming source range select	0-5 V (0-5 k)	<u>0-10 V</u> (0-10 k)
SW1-5	Output voltage monitor setting	Not available	<u>0-10 V</u>
SW1-6	Output current monitor setting	Not available	<u>0-10 V</u>
SW1-7	Remote shutdown logic select	<u>HIGH=OFF</u>	HIGH=ON
SW1-8	Over heat shutdown reset mode select	Auto reset	<u>Latch OFF</u>

Resetting the Switches

Before making any changes to the switch settings, disable the power supply output by pushing the front panel STANDBY switch to its IN position. This shuts down the power supply on a temporary basis. The front panel S/D LED turns on. Then use any small, flat-bladed screwdriver to change the switch settings.

Any of the eight switches on SW1 is OFF (OPEN) when it has been flipped up to break contact, ON (CLOSED) when flipped down to close contact.

1.4.2 Rear Panel J2 Connector

The J2 Programming and Monitoring connector is a 15-terminal wire clamp connector located on the power supply's rear panel. See Figure 1.4-3. The J2 connector provides access to the following functions:

- Remote programming of output voltage AND/OR current limit
- Remote monitoring of calibrated readback signals for output voltage and output current
- Remote control of the shutdown function using a 2.5 V to 15 V signal

- 1 Remote Output Voltage Programming Select
- 2 Remote Output Current Limit Programming Select
- 3 Control Ground
- 4 No connection
- 5 Voltage Program Signal Return
- 6 Output Voltage Programming Input
- 7 Current Program Signal Return
- 8 Output Current Limit Programming Input
- 9 Voltage Monitor Signal Return
- 10 Output Voltage Monitor
- 11 Current Monitor Signal Return
- 12 Output Current Monitor
- 13 No connection
- 14 Shutdown (S/D) Signal Return (-)
- 15 S/D Input (+)

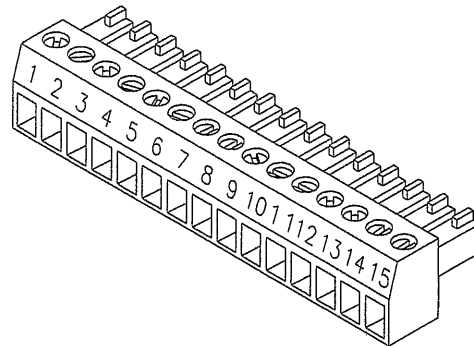

Figure 1.4-3 Programming and Monitoring J2 Connector

See Table 1.4-2 for a list of the J2 connector terminal numbers, their references, and corresponding functions.

Table 1.4-2 Rear Panel J2 Connector Terminals and Functions

Connector	Reference	Name	Function
J2-1	VRMT	Remote Output Voltage Programming Select	Selects remote output voltage programming when jumpered to pin 3.
J2-2	IRMT	Remote Output Current Limit Programming Select	Selects remote output current limit programming when jumpered to pin 3.
J2-3	CNTL GND	Control Ground	Control ground.
J2-4	N/C	No connection	None.
J2-5	VPGM-	Voltage Program Signal Return	Return for voltage program signal.
J2-6	VPGM	Output Voltage Programming Input	Input for voltage programming signals from an analog device.
J2-7	IPGM-	Current Program Signal Return	Return for current program signal.
J2-8	IPGM	Output Current Limit Programming Input	Input for current limit programming signals from an analog device.
J2-9	VMON-	Voltage Monitor Signal Return	Return for voltage monitor signal.
J2-10	VMON	Output Voltage Monitor	Output for output voltage monitor signal.
J2-11	IMON-	Current Monitor Signal Return	Return for current monitor signal.
J2-12	IMON	Output Current Monitor	Output for output current monitor signal.
J2-13	N/C	No connection	None.
J2-14	S/D-	Shutdown Signal Return (-)	Return for shutdown signal.
J2-15	S/D+	S/D Input (+)	Input for shutdown signal.

1.4.2 Rear Panel J2 Connector (continued)

Making J2 Connections

CAUTION

Do not attempt to bias program/monitor signal return (J2 terminals 5, 7, 9, and 11) relative to the supply output because control ground (J2-3) and the program/monitor signal returns are at the same potential as the power supply return in a standard unit.

CAUTION

To maintain the isolation of the power supply output and prevent ground loops, use an isolated (ungrounded) programming source when operating the power supply via remote analog control at the J2 connector.

Make connections to the J2 connector using its screw-type wire clamps. Before making any connections, turn the power supply OFF and wait until the front panel displays have gone out. You can unplug the connector from the back of the unit in order to make it easier to install the required wiring.

Wiring



WARNING

There is a potential shock hazard at the output when using a power supply with a rated output greater than 40 V. Use load wiring with a minimum insulation rating equivalent to the maximum output voltage of the power supply. For example, select TEW-105, 105 °C, 600 V wiring for use with a 600 V, 2 A model power supply.

For most connectors and jumpers, use any suitable wire such as 16 to 24 AWG stranded wire. For lowest noise performance, use shielded pair wiring of 16 to 24 AWG. Strip wires 0.26" (6.5 mm), insert, and tighten the wire clamp.

1.5 Specifications

1.5.1 Electrical Specifications

These specifications are warranted over a temperature range of 0 °C to 50 °C. Nominal ambient temperature assumed is 25 °C. Nominal line voltages are 100 Vac and 200 Vac. See Table 1.5-1 and Table 1.5-2 for maximum values for model-dependent specifications. Specifications are subject to change without notice.

Table 1.5-1 Electrical Specifications for 7.5 V to 60 V Models

Models	7.5-140	12-100	20-60	40-30	60-20
Output Ratings:					
Output Voltage ¹	0-7.5 V	0-12 V	0-20 V	0-40 V	0-60 V
Output Current ²	0-140 A	0-100 A	0-60 A	0-30 A	0-20 A
Output Power	1050 W	1200 W	1200 W	1200 W	1200 W
Line Regulation: ³					
Voltage (0.01% of Vmax + 2 mV)	5.75 mV	8 mV	12 mV	22 mV	32 mV
Current (0.01% of Imax + 2 mA)	72 mA	52 mA	32 mA	17 mA	12 mA
Load Regulation: ⁴					
Voltage (0.02% of Vmax + 5 mV)	11 mV	14 mV	20 mV	35 mV	50 mV
Current (0.02% of Imax + 5 mA)	110 mA	80 mA	50 mA	27.5 mA	20 mA
Meter Accuracy:					
Voltage (1% of Vmax + 1 count)	0.09 V	0.13 V	0.3 V	0.5 V	0.7 V
Current (1% of Imax + 1 count)	1.5 A	1.1 A	0.7 A	0.4 A	0.3 A
Output Noise (0-20 MHz): Voltage (p-p)	75 mV	75 mV	75 mV	150 mV	150 mV
Output Ripple (rms):					
Voltage	10 mV	10 mV	10 mV	10 mV	10 mV
Current ⁵	800 mA	800 mA	500 mA	500 mA	500 mA
Drift (30 minutes): ⁶					
Voltage (0.05% of Vmax)	3.75 mV	6 mV	10 mV	20 mV	30 mV
Current (0.8% of Imax)	1120 mA	800 mA	480 mA	240 mA	160 mA
For Resistive Programming:					
Voltage (0.6% of Vmax)	45 mV	72 mV	120 mV	240 mV	360 mV
Current (0.6% of Imax)	840 mA	600 mA	360 mA	180 mA	120 mA
Drift (8 hours): ⁷					
Voltage (0.05% of Vmax)	3.75 mV	6 mV	10 mV	20 mV	30 mV
Current (0.05% of Imax)	70 mA	50 mA	30 mA	15 mA	10 mA
For Resistive Programming:					
Voltage (0.3% of Vmax)	22 mV	36 mV	60 mV	120 mV	180 mV
Current (0.3% of Imax)	420 mA	300 mA	180 mA	90 mA	60 mA
Temperature Coefficient: ⁸					
Voltage (0.02% of Vmax/°C)	1.5 mV	2.4 mV	4 mV	8 mV	12 mV
Current (0.03% of Imax/°C)	42 mA	30 mA	18 mA	9 mA	6 mA
For Resistive Programming:					
Voltage (0.06% of Vmax/°C)	4.5 mV	7.2 mV	12 mV	24 mV	36 mV
Current (0.06% of Imax/°C)	84 mA	60 mA	36 mA	18 mA	12 mA
OVP Adjustment Range: (5% to 110% of Vmax)					
	0.375-8.25 V	0.6-13.2 V	1-22 V	2-44 V	3-66 V
Efficiency: ⁹	0.78	0.81	0.81	0.83	0.86

1. Minimum output voltage is <0.15% of rated voltage at zero output setting.
2. Minimum output current is <0.5% of model-rated current at zero output setting, when measured at minimum 10% of full power load.
3. For input voltage variation over the AC input voltage range, with constant rated load.
4. For 0-100% load variation, with constant nominal line voltage.
5. Current mode noise is measured from 10% to 100% of rated output voltage, full current.
6. Maximum drift over 30 minutes with constant line, load, and temperature, after power on.
7. Maximum drift over 8 hours with constant line, load, and temperature, after 30-minute warm-up.
8. Change in output per °C change in ambient temperature, with constant line and load.
9. Typical efficiency at 100 Vac input voltage and rated output power.

1.5.1 Electrical Specifications (continued)

Table 1.5-2 Electrical Specifications for 100 V to 600 V Models

Models	100-12	150-8	300-4	600-2
Output Ratings:				
Output Voltage ¹	0-100 V	0-150 V	0-300 V	0-600 V
Output Current ²	0-12 A	0-8 A	0-4 A	0-2 A
Output Power	1200 W	1200 W	1200 W	1200 W
Line Regulation: ³				
Voltage (0.01% of Vmax + 2 mV)	52 mV	77 mV	152 mV	302 mV
Current (0.01% of Imax + 2 mA)	8 mA	6 mA	4 mA	3 mA
Load Regulation: ⁴				
Voltage (0.02% of Vmax + 5 mV)	80 mV	118 mV	230 mV	455 mV
Current (0.02% of Imax + 5 mA)	14 mA	11 mA	8 mA	6.5 mA
Meter Accuracy:				
Voltage (1% of Vmax + 1 count)	1.1 V	1.6 V	4 V	7 V
Current (1% of Imax + 1 count)	0.13 A	0.09 A	0.05 A	0.03 A
Output Noise (0-20 MHz): Voltage (p-p)	150 mV	150 mV	200 mV	400 mV
Output Ripple (rms):				
Voltage	10 mV	20 mV	30 mV	80 mV
Current ⁵	200 mA	200 mA	200 mA	200 mA
Drift (30 minutes): ⁶				
Voltage (0.05% of Vmax)	50 mV	75 mV	150 mV	300 mV
Current (0.8% of Imax)	96 mA	64 mA	32 mA	16 mA
For Resistive Programming:				
Voltage (0.6% of Vmax)	600 mV	900 mV	1800 mV	3600 mV
Current (0.6% of Imax)	72 mA	48 mA	24 mA	12 mA
Drift (8 hours): ⁷				
Voltage (0.05% of Vmax)	50 mV	75 mV	150 mV	300 mV
Current (0.05% of Imax)	6 mA	4 mA	2 mA	1 mA
For Resistive Programming:				
Voltage (0.3% of Vmax)	300 mV	450 mV	900 mV	1800 mV
Current (0.3% of Imax)	36 mA	24 mA	12 mA	6 mA
Temperature Coefficient: ⁸				
Voltage (0.02% of Vmax/°C)	20 mV	30 mV	60 mV	120 mV
Current (0.03% of Imax/°C)	3.6 mA	2.4 mA	1.2 mA	0.6 mA
For Resistive Programming:				
Voltage (0.06% of Vmax/°C)	60 mV	90 mV	180 mV	360 mV
Current (0.06% of Imax/°C)	7.2 mA	4.8 mA	4.2 mA	1.2 mA
OVP Adjustment Range:				
(5% to 110% of Vmax)	5-110 V	7.5-165 V	15-330 V	30-660 V
Efficiency: ⁹	0.84	0.84	0.84	0.85

1. Minimum output voltage is <0.15% of rated voltage at zero output setting.
2. Minimum output current is <0.5% of model-rated current at zero output setting, when measured at minimum 10% of full power load.
3. For input voltage variation over the AC input voltage range, with constant rated load.
4. For 0-100% load variation, with constant nominal line voltage.
5. Current mode noise is measured from 10% to 100% of rated output voltage, full current.
6. Maximum drift over 30 minutes with constant line, load, and temperature, after power on.
7. Maximum drift over 8 hours with constant line, load, and temperature, after 30-minute warm-up.
8. Change in output per °C change in ambient temperature, with constant line and load.
9. Typical efficiency at 100 Vac input voltage and rated output power.

1.5.2 Additional Specifications

Rise Time (No Load, Full Load): ¹	7.5 V to 60 V models: 100 ms; 100 V to 600 V models: 170 ms
Fall Time (No Load): ²	7.5 V to 60 V models: 3 s; 100 V to 600 V models: 4 s
Fall Time (Full Load): ³	7.5 V to 60 V models: 100 ms; 100 V to 600 V models: 170 ms
Voltage Mode Transient Response: ⁴	<3 ms
Time Delay from power on until output stable	7 s maximum

1.5.3 Input Conditions

Rated AC Input Voltage	100/120/220/230/240 Vac (nominal) ±10% 200 Vac -5%, +10%
Maximum AC Input Power	2600 VA
Operational AC Input Voltage	85-130 Vac or 190-264 Vac, 1φ. Auto range select function.
Maximum Input Current	24 A maximum at 100 Vac; 14 A maximum at 200 Vac.
Source Frequency	47-63 Hz
Power Factor	0.65 minimum at full load and 100 Vac input; 0.55 minimum at full load and 200 Vac input

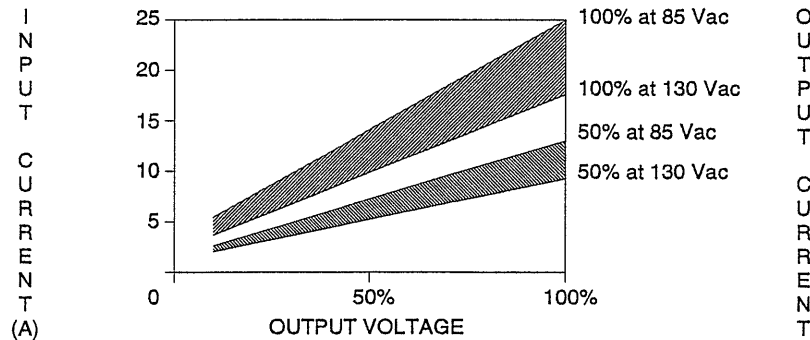

Figure 1.5-1 Typical Input Current Characteristics, 85-130 Vac Range
(Based on 60 V, 20 A model.)

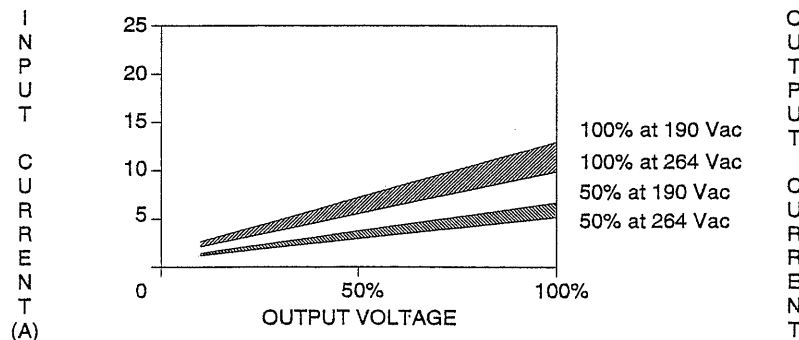

Figure 1.5-2 Typical Input Current Characteristics, 190-264 Vac Range
(Based on 60 V, 20 A model.)

1. Measured with stepped 0-10 V analog programming source and a resistive load.
2. Measured with stepped 0-10 V analog programming source and a resistive load.
3. Measured with stepped 0-10 V analog programming source and a resistive load.
4. Time for the output voltage to recover within 0.5% of its rated value after a step change in load current of 10% to 90% of rated output, with an output set point between 50-100% of rated value. Load slew rate <6 A/μs.

1.5.4 Additional Characteristics

Switching Frequency	7.5 V to 40 V models: nominal 78 kHz (156 kHz output ripple); 60 V to 600 V models: nominal 62.5 kHz (125 kHz output ripple)
Output Hold-up Time	Greater than 20 ms with interruption of AC line, for nominal AC input and full load
Maximum Voltage Differential from either output to safety ground	±600 Vdc

1.5.5 Remote Programming and Monitoring

Remote Start/Stop and Interlock	2.5 V to 15 V signal or TTL-compatible input, selectable logic. TTL input impedance: 2 k (in series with one diode drop).
Remote Analog Programming (Full Scale Input)	Voltage and current programming inputs (source must be isolated): 0-5 k, 0-10 k resistances; 0-5 V, 0-10 V (default) voltage sources. Input impedance (V and I): approximately 100 k.
Remote Monitoring	Output voltage and current: 0-10 V (default). Output impedance (V and I): approximately 221 Ω Output short circuit current: approximately 50 mA.
Remote Programming and Monitoring Accuracy	1% zero to full scale output for the default range.
Maximum Remote Sense Line Drop Compensation	5 V/line (Line drop is subtracted from total voltage available at supply output.)
Optional Digital Control	GPIB interface

1.5.6 Environmental Specification

Operating Temperature Range	0 °C to 50 °C
Storage Temperature Range	-20 °C to +70 °C
Humidity Range	30% to 90% RH non-condensing
Installation Category	Intended for use in installation category (overvoltage category) II (IEC 1010-1 standard).
Pollution Degree	Category 2 (IEC 1010-1 standard).

1.5.7 Mechanical Specification

Front Panel V and I Control	10-turn voltage and current potentiometers
Front Panel Voltage Control Resolution	0.02% of full scale (theoretical value)
Front Panel Voltage and Current Meters	3.5-digit red numeric LED displays. For accuracy specifications, see Table 1.5-1 and Table 1.5-2.
AC Input Connector Type	3-terminal 34 A, 250 V, right angle, PC mount, wire clamp connector with removable strain relief cover

1.5.7 Mechanical Specification (continued)

Input Fuses ¹	1 A, 250 V, 5 x 20 mm slow fuse (T), location: F34; 2 A, 250 V, 5 x 20 mm time delay (T), location: F95; 10 A, 250 Vac, 5 x 20 mm fast high interrupt (F), location: F29; 30 A, 300 Vac, 10.3 x 41.3 mm medium time lag (T), locations: F2, F4.
Output Connector	7.5 V to 40 V models: nickel-plated copper bus bars with removable bus bar shield; bus bar holes: 0.332" (8.17 mm) diameter (D) (1), 0.197" (5.0 mm) D (2); 60 V to 600 V models: 4-terminal wire clamp connector with removable shield and strain relief.
Sense Connector	5-terminal wire clamp connector (2 piece)
Analog Programming Connector	15-terminal wire clamp connector (2 piece)
Chassis Ground	Two chassis ground screws located on rear panel for bonding connections or for wire shield grounding.
Cooling	Fan cooled. Air exhausts to rear. Over temperature shutdown: automatic restart or latch off (switch selectable).
Mounting	Removable rack mount brackets at front panel.
Weight	Approximately 18 lb. (8.2 kg)
Approvals	CE-marked units meet IEC 1010-1 safety standard and EN50081-2 and EN50082-1 EMC standards. Additional standards: CSA C22.2 No. 1010.1, UL 3111-1, and FCC, part 15, class A EMI standard.

1. Fuses are located on the A4 PCB (printed circuit board). The fuses are NOT operator-replaceable.

1.5.7 Mechanical Specification (continued)

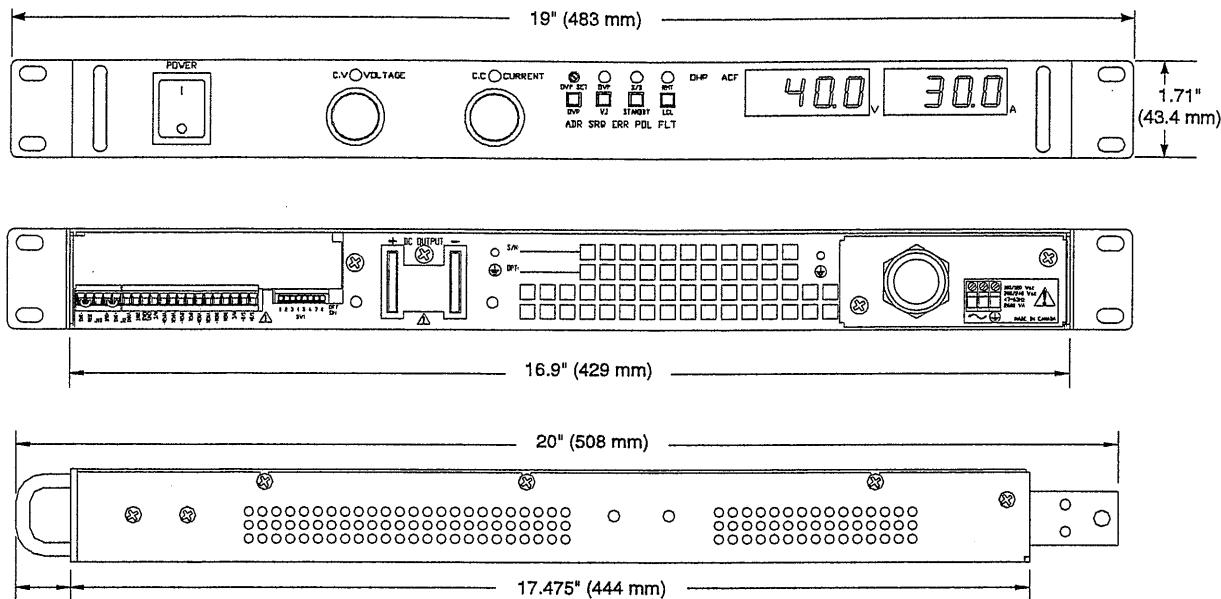

Figure 1.5-3 Dimensional Drawings
(Dimensions given are nominal.)

1.5.8 Insulation Resistances and Withstanding Voltages

Insulation Resistance ¹

Input to chassis: >30 MΩ, with 500 Vdc;
Output to chassis: >20 MΩ, with 1000 Vdc.

Withstanding Voltages

Input to chassis: no change for 1 minute at 1500 Vac;
Input to output: no change for 1 minute at 1500 Vac.

1. Humidity <70% RH.

2. INSTALLATION

2.1 Introduction

This section provides recommendations and procedures for inspecting, installing, and testing the power supply.

2.2 Basic Setup Procedure

See Table 2.2-1 for a summary of the basic setup procedure and an overall view of the subsections in Section 2. Use the procedure as a quick reference if you are familiar with the installation requirements for the power supply. If you want more information, each step in the procedure refers to subsequent sections which contain more details. Execute each step in the sequence given.

Table 2.2-1 Basic Setup Procedure

Step #	Description	Action	Reference
1	Inspection	Perform an initial physical inspection of the supply.	Section 2.3 Inspection, Cleaning, and Packaging
2	Installation	Install the supply (bench or rack mount), ensuring adequate ventilation.	Section 2.4 Location, Mounting, and Ventilation
3	Input Power	Connect AC input power.	Section 2.5 AC Input Power
4	Test	Perform functional tests for voltage mode operation, current mode operation, and front panel controls.	Section 2.6 Functional Tests
5	Load	Connect the load.	Section 2.7 Load Connection
6	Sensing	Connect sensing lines.	Section 2.8 Local and Remote Sensing

See Section 3. Local Operation for instructions for front panel operation, over voltage and over heat protection, shutdown, and using multiple supplies. You will find remote programming and monitoring described in Section 4. Remote Operation.

2.3 Inspection, Cleaning, and Packaging

2.3.1 Initial Inspection

When you first receive your unit, perform a quick physical check.

1. Inspect the unit for scratches and cracks, and for broken switches, connectors, and displays.
2. Ensure that the packing box contains the AC input cover and strain relief kit (see Figure 2.5-1). For 60 V to 600 V models, check that the box also contains the output cable strain relief (see Figure 2.7-4). For all models, the output shield is already installed.
3. Have the service technician check the printed circuit board and its components if you suspect internal damage.

If the unit is damaged, save all packing materials and notify the carrier immediately. See packing instructions in Section 2.3.3.

2.3.2 Periodic Cleaning

No routine servicing of the power supply is required except for periodic cleaning. Whenever a unit is removed from operation, clean the metal surfaces with naphtha or an equivalent solvent and the front panel with a weak solution of soap and water. Use low-pressure compressed air to blow dust from in and around components on the printed circuit boards.

2.3.3 Packaging for Shipping or Storage

Follow these instructions to prepare the unit for shipping or storage.

1. When returning the unit or sending it to the service center, attach a tag to the unit stating its model number (available from the front panel label) and its serial number (available from the rear panel label). Give the date of purchase and an invoice number, if you have it, as well as a brief description of the problem.
2. For storage or shipping, repack the power supply in its original container. If the original container is not available, seal the unit in a plastic bag and then pack it in a 200 lb. test (90 kg), corrugated cardboard carton large enough to allow 2" (5 cm) of cushioning material to surround the unit. Use a material such as foam slabs or chips.
3. Label the carton as shown in Figure 2.3-1.
4. If shipping, mark the address of the service center and your return address on the carton.
5. If storing, stack no more than eight cartons high. Check the storage temperature range in Section 1.5.6.

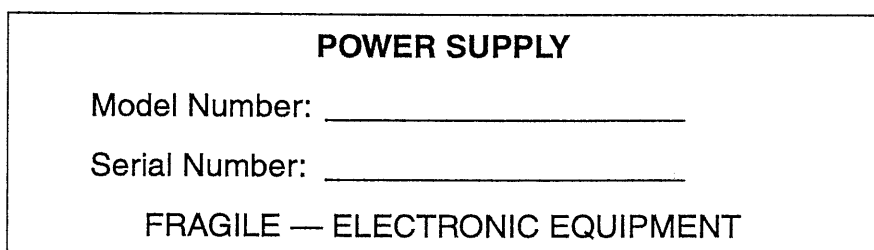
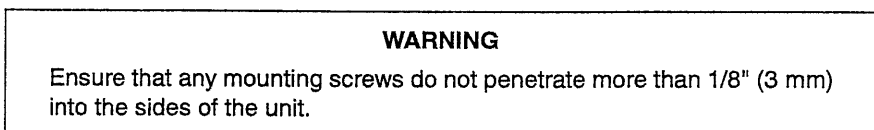

Figure 2.3-1 Shipping or Storage Carton Label

2.4 Location, Mounting, and Ventilation

Use the power supply in rack mounted or in benchtop applications.

2.4.1 Rack Mounting



The power supply is designed to fit in a standard 19" (483 mm) equipment rack. To install:

1. Use the rack-mount brackets at either side of the front panel to install the power supply in a rack.
2. Provide adequate support for the rear of the unit without obstructing the ventilation inlets on the sides of the unit. Call our dealer or branch office to order an optional support bar for our 19" rack. Follow the manufacturer's instructions to install the support bar.

Angle Bracket Mounting

Rack mount slides are not suitable for the 1200 watt unit, however, angle brackets are available from the manufacturer.

2.4.2 Ventilation

CAUTION

Do not use the unit in a flammable atmosphere.
Avoid locations where the unit is exposed to high temperature or direct sunlight.
Avoid locations of high humidity.
Do not place the unit in a corrosive atmosphere.
Do not place the unit in a dusty location.
Do not operate the unit where ventilation is poor.
Do not install the unit along a tilted section of floor or in a location subject to vibrations.
Do not use the unit in locations affected by strong magnetic and/or electric fields.

Whether you place the power supply in a rack or on a bench, allow cooling air to reach the ventilation inlets on the sides of the unit and allow 4" (10 cm) of unrestricted air space at the rear of the unit for the fan exhaust. Any ventilation space at the top and bottom of the supply will further lower internal operating temperatures.

Ensure the maximum ambient temperature does not exceed 40 °C when operating power supplies stacked in a 19" (483 mm) rack. When installing the power supplies in the rack, reserve a space corresponding to the height of a single power supply (1 U) between each stack of two power supplies. If you do not maintain this spacing, the temperature inside the power supplies will increase and may cause a shutdown or other fault.

When you stack the power supplies using a JIS-type rack such as our KRO1600 or RC232 rack, it is possible to install a maximum of 32 power supplies.

2.5 AC Input Power

WARNING

There is a potential shock hazard if the power supply chassis and cover are not connected to an electrical ground via the safety ground in the AC input connector. Ensure that the power supply is connected to a grounded AC outlet with the recommended AC input connector configured for the available line voltage as set out in this section.

WARNING

Disconnect AC power from the unit before removing the cover. Even with the front panel power switch in the OFF position, live line voltages are exposed when the cover is removed. Repairs must be made by experienced service technicians only.

CAUTION

When power switch is turned on, output voltage or current previously set will be applied to loads.

2.5.1 AC Input Connector and Voltage Selection

The AC input connector is a 3-terminal wire clamp connector located on the power supply's rear panel. See Figure 2.5-1 AC Input Cover and Strain Relief.

Auto Range Select



CAUTION

To prevent damage to the power supply, turn off AC power to the unit before changing from one AC input voltage range to another.

The Auto Range Select function built into the 1200 watt unit allows you to connect to either low or high AC input voltages without making any adjustments to the unit. We warrant that the unit will perform to specification at AC input voltage ranges 85 to 130 Vac and 190 to 264 Vac. See Table 2.5-1. Between these ranges (at 130 to 190 Vac), the unit will operate normally, although full performance to specification cannot be guaranteed.

Table 2.5-1 Operational AC Input Voltage Ranges and Frequency

AC Voltage Range	Frequency
85-130 Vac 1 ϕ (24 A maximum at 100 Vac)	47-63 Hz
190-264 Vac 1 ϕ (14 A maximum at 200 Vac)	47-63 Hz

AC Fail LED

The AC Fail (ACF) LED turns on when the input voltage is outside of the range specified for the power supply. The LED turns off when the input voltage is within the range.

2.5.2 AC Input Cord



WARNING

The AC input cord is the disconnect device for the power supply. The plug must be readily identifiable by and accessible to the operator. The input cord must be no longer than 9.84 feet (3 m).

The AC input wire we recommend is specified in Table 2.5-2 AC Wire Specification. Add a non-locking plug suitable for use in the country in which you are operating. If you require a special cord, call us.

Table 2.5-2 AC Wire Specification

Wire Size	Ratings	Cable Outside Diameter
3 x 12 AWG stranded copper	SJT or SOOW, 105 °C	0.545-0.708" (13.63-17.7 mm)
3 x 16 AWG stranded copper ¹	SJT or SOOW, 105 °C	0.545-0.708" (13.63-17.7 mm)

1. Alternate choice for 190-264 Vac input only.

2.5.3 AC Input Wire Connection

1. Strip the outside insulation on the AC cable approximately 4" (10 cm). Trim the wires so that the ground wire is 0.5" (12 mm) longer than the other wires. Strip 0.55" (14 mm) at the end of each of the wires. See Figure 2.5-1 detail (top).
2. Unscrew the base of the strain relief from the helix-shaped body. Insert the base through the outside opening in the AC input cover and, from the inside, screw the locknut securely onto the base.
3. Slide the helix-shaped body onto the AC cable. Insert the stripped wires through the strain relief base until the outer cable jacket is flush with the edge of the base. Tighten the body to the base while holding the cable in place. The cable is now securely fastened inside the strain relief.
4. Route the AC wires to the input connector terminals as required. For input connector terminal locations, see lower inset in Figure 2.5-1. To connect the wiring, loosen the terminal screw, insert the stripped wire into the terminal, and tighten the screw securely.

CAUTION — CONNECTING WIRING TO TERMINAL

Do not twist the stripped wires. Insert the stripped wires into the terminal securely and tighten the screw using a cabinet-style screwdriver with a blade size of 4 x 0.5.

5. Route the wires inside the cover to prevent pinching. Fasten the AC input cover to the unit using the (6-32 x 1 1/4" (2)) screws, flat washers, and lock washers provided. See Figure 2.5-1.

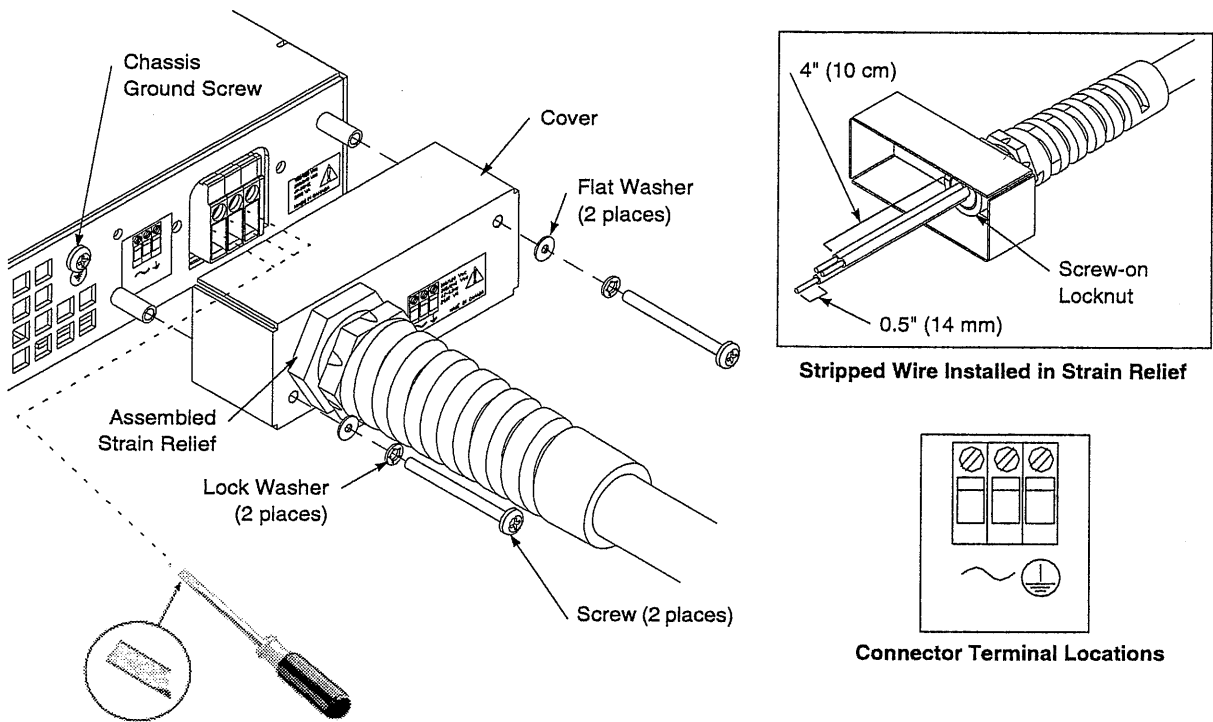

Figure 2.5-1 AC Input Cover and Strain Relief

2.6 Functional Tests

These functional test procedures include power-on and front panel function checks as well as voltage and current mode operation checks. Refer to front and rear panel diagrams in Section 2.3.

2.6.1 Equipment Required

- Digital Voltmeter (DVM) rated better than 0.5% accuracy.
- DC shunt 1 mV/A ($\pm 0.25\%$) with connecting wire. The recommended current ratings for the DC shunt and the wire must be at least 10% more than the output current of the power supply.

2.6.2 Power-on Check

1. Ensure that the AC power switch is in the OFF position.
2. Ensure that the output sense lines are connected in the default configuration. (The local sense lines are connected between terminals 1 and 2 and between terminals 4 and 5 on the J10 sense connector as shown on the rear panel diagram in Figure 1.4-1.)
3. Turn the voltage and current controls fully counter-clockwise.
4. Connect the unit to an AC outlet.
5. Turn the front panel AC power switch to ON.

After a short power-on delay, the front panel digital meters light up and the green voltage mode LED turns on. Both voltmeter and ammeter displays read zero.

2.6.3 Voltage Mode Operation Check

1. Ensure the voltage and current controls on the front panel are turned fully counter-clockwise.
2. Connect a DVM to the output terminals on the rear panel, observing correct polarity.
3. Turn the current control one 1/2-turn clockwise. Slowly turn the voltage control clockwise and observe both the front panel voltmeter and the DVM.
4. Compare the DVM reading with the front panel voltmeter reading to verify the accuracy of the internal voltmeter. Both readings should be the same. The minimum control range is from zero to the maximum rated output for the power supply model. The voltage mode LED turns on.
5. Turn the front panel AC power switch to OFF.

2.6.4 Current Mode Operation Check

1. Ensure the front panel AC power switch is set to OFF.
2. Turn the voltage and current controls on the front panel fully counter-clockwise.
3. Connect the DC shunt across the output terminals on the rear panel.
4. Connect the DVM across the DC shunt.
5. Turn the AC power switch to ON.
6. Turn the voltage control one (1) or two (2) turns clockwise.
7. Turn the current control slowly clockwise.
8. Compare the DVM reading with the front panel ammeter reading using $I=V/R$ where I is the current, V is the DVM reading, and R is the DC shunt resistance. The minimum control range is from zero to the maximum rated output for the power supply model. The current mode LED turns on.
9. Turn the AC power switch to OFF.
10. Disconnect the DVM and the shunt.

2.6.5 Front Panel Function Checks

1. Turn the front panel AC switch to ON.
2. Set voltage and current controls fully clockwise. Push the STANDBY switch to its IN position and check that the voltmeter reading falls to zero and the red S/D (Shutdown) LED turns on. Push the STANDBY switch once again to reset it to its OUT position. The S/D LED turns off and the voltmeter reading returns to its previous value.
3. Press the STANDBY switch to its IN position.
4. Press the OVP PRESET switch and check that the voltmeter displays approximately the model-rated output voltage plus 10%.
5. Turn the OVP SET potentiometer counter-clockwise and check that the voltmeter reading decreases. Continued turning (up to 20 turns) will see the reading decrease to approximately 5% of the model-rated voltage output. Turn the OVP SET potentiometer clockwise until the voltmeter once again displays approximately the model-rated output voltage plus 10%.
6. Press the STANDBY switch to its OUT position.
7. Press the V-I PRESET switch and check that the voltmeter and ammeter display approximately the power supply output ratings.
8. Turn the front panel AC power switch to OFF.

Note: You can use the front panel LCL button only when a digital programming interface has been installed in your power supply.

2.7 Load Connection

This section provides recommendations for load wires and how to connect them for both single and multiple load configurations.

2.7.1 Load Wiring

When connecting load wiring to the power supply, consider the following factors:

- insulation rating of the wire
- current carrying capacity of the wire
- maximum load wiring length for operation with sense lines
- noise and impedance effects of the load lines

Insulation Rating

Use load wiring with a minimum insulation rating equivalent to the maximum output voltage of the power supply. For example, select TEW-105, 105 °C, 600 V wiring for use with a 600 V, 2 A model power supply.

Current Carrying Capacity

As a minimum, load wiring must have a current capacity greater than the output current rating of the power supply. This ensures that the wiring will not be damaged even if the load is shorted. Table 2.7-1 shows the maximum current rating, based on 450 A/cm², for various gauges of wire rated for 105 °C operation. Operating at the maximum current rating results in approximately a 30 °C temperature rise for a wire operating in free air. Where load wiring must operate in areas with elevated ambient temperatures or bundled with other wiring, use larger gauges or wiring rated for higher temperatures.

Table 2.7-1 Current Carrying Capacity for Load Wiring

Wire Size (AWG)	Maximum Current (A)	Wire Size (AWG)	Maximum Current (A)
20	2.5	6	61
18	4	4	97
16	6	2	155
14	10	1	192
12	16	1/0	247
10	21	2/0	303
8	36		

Load Wiring Length for Operation with Sense Lines

For applications using remote sensing, you must limit the voltage drop across each load line. Figure 2.7-1 shows some maximum allowable wire lengths for a given load current and wire size. We recommend you use the larger load wiring to ensure a smaller voltage drop (1 V typical maximum), although units will compensate for up to 5 V drop in each line. See also Section 2.8 Local and Remote Sensing.

2.7.1 Load Wiring (continued)

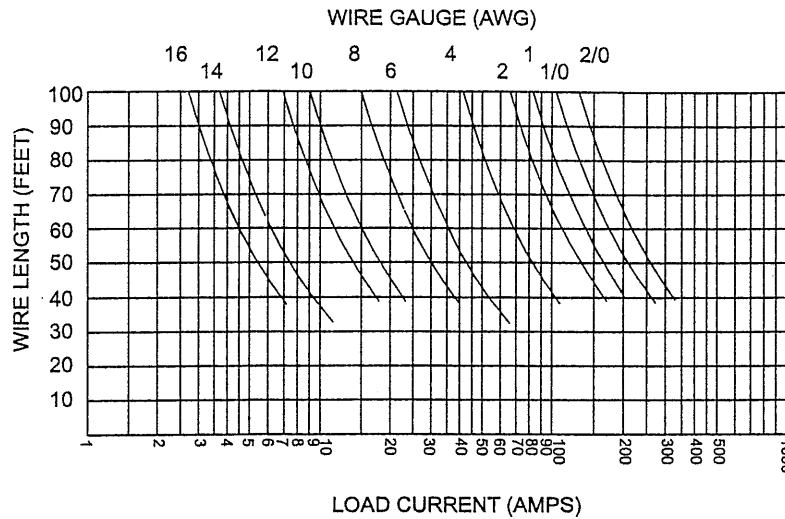

Figure 2.7-1 Maximum Load Wire Length for 1 V Line Drop

Noise and Impedance Effects

To minimize noise pickup or radiation, use shielded pair wiring of as short a length as possible for load wires. Connect the shield to the chassis via a rear panel mounting screw. Where shielding is impossible or impractical, simply twisting the wires together will offer some noise immunity. When using local sense connections, use the largest practical wire size to minimize the effects of load line impedance on the regulation of the supply.

2.7.2 Making Load Connections

⚠ WARNING

There is a shock hazard at the load when using a power supply with a rated output greater than 40 V. To protect personnel against accidental contact with hazardous voltages, ensure that the load, including connections, has no live parts which are accessible. Also ensure that the insulation rating of the load wiring and circuitry is greater than or equal to the maximum output voltage of the power supply.

CAUTION

When making connections to the bus bars, ensure that each terminal's mounting hardware and wiring assembly are placed to avoid touching the other terminal and shorting the power supply output. Heavy connecting cables must have some form of strain relief to avoid loosening the connections or bending the bus bars.

Make load connections at the rear of the power supply at the positive and negative output bus bars or to the 4-terminal wire clamp connector, depending on the model.

2.7.2 Making Load Connections (continued)

7.5 V to 40 V Models

The 7.5 V to 40 V (low voltage) models have output bus bars and may come with a bus bar shield in some configurations. To detach the shield before connecting load wires, remove 6-32 x 1/4" screws (2), 6-32 x 3/8" screw (1), and lock washers and flat washers (3 places). See Figure 2.7-2.

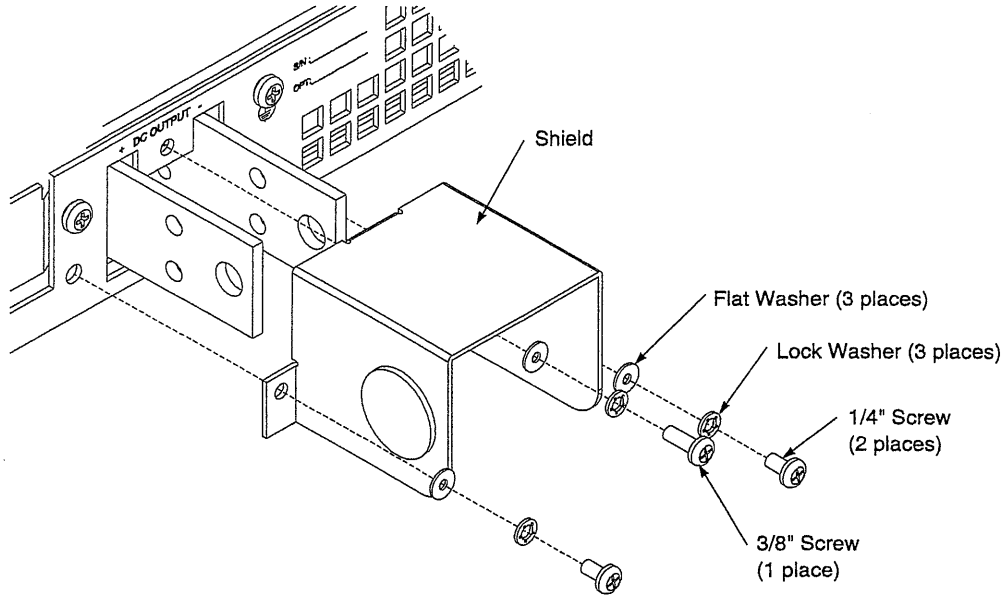

Figure 2.7-2 Bus Bar Shield

To make load connections to a 7.5 V, 140 A power supply:

1. Install a connecting wire terminal lug to load wiring (see Figure 2.7-3).
2. Fasten connectors to bus bars with 1/4" x 1/2" (M6 x 14 mm) screws and internal tooth lock washers, and hex nuts as shown in Figure 2.7-3.

Note: Bus bar hole sizes for the low voltage models are: 1 of 0.332" (8.17 mm) D; and 2 of 0.197" (5.0 mm) D.

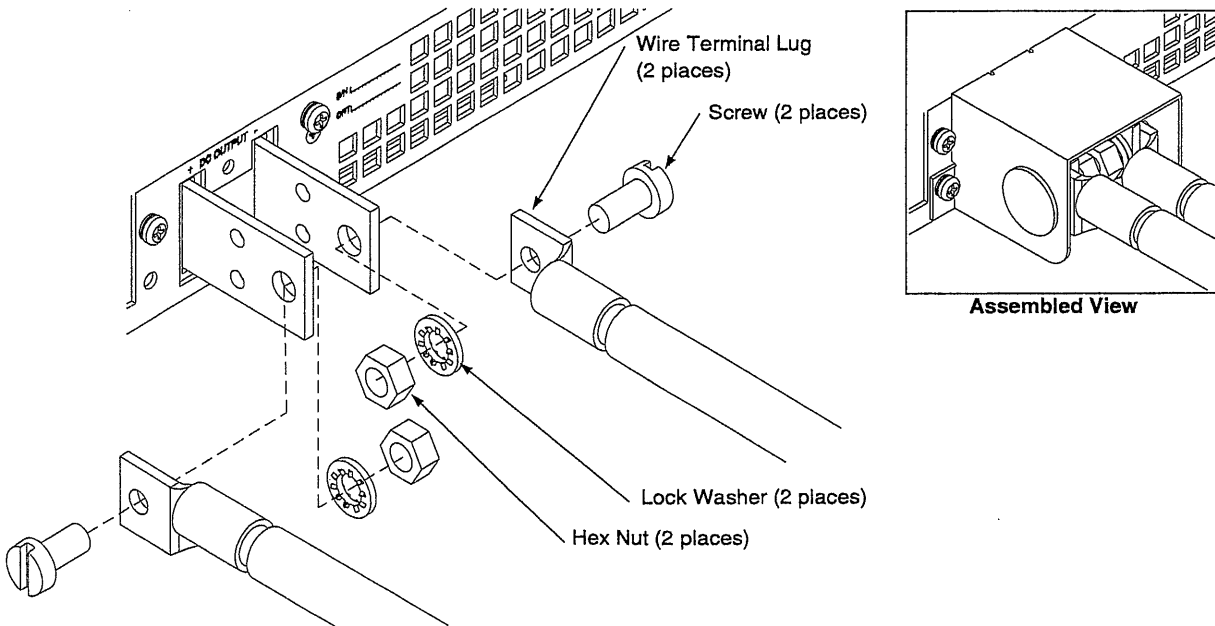

Figure 2.7-3 Typical Load Connection Hardware
(Low voltage model shown.)

2.7.2 Making Load Connections (continued)

60 V to 600 V Models

WARNING

To protect personnel against accidental contact with hazardous voltages, ensure that the load, including connections, has no live parts which are accessible. Also ensure that the insulation rating of the load wiring and circuitry is greater than or equal to the maximum output voltage of the power supply.

WARNING

Wear protective gloves and use caution when removing the circular knockout from the shield as described below. The exposed metal edges of the knockout may be sharp.

The 60 V to 600 V (high voltage) models have a 4-terminal, wire clamp output connector. See inset of Figure 2.7-4 for a labelled drawing of the wire clamp connector. The units are shipped with a protective shield attached (see Figure 2.7-4). To prepare and connect the load wiring:

1. Use a gloved finger or a blunt tool to push in the circular knockout on the right side (recommended) of the shield. After you push in the knockout, twist until it detaches from the shield. Discard the knockout.
2. Insert the bushing of the small black strain relief, screw-side out, through the knockout hole, pushing in from the outside of the shield. You will hear a snap as the strain relief attaches securely to the shield.
3. Strip insulation 0.35" (9 mm) at the end of each of the wires.
4. Loosen the strain relief screw and route the wires through the strain relief.
5. Loosen the connector terminal screw (see inset in Figure 2.7-4), insert the stripped wire into the terminal, and tighten the terminal screw securely.

CAUTION — ATTACHING THE LOAD WIRE

Insert the load wire through the strain relief before connecting the load wire to the output voltage connector.

6. Ensure that the wires are not pulled too taut between the terminals and the strain relief. Tighten the strain relief screw.

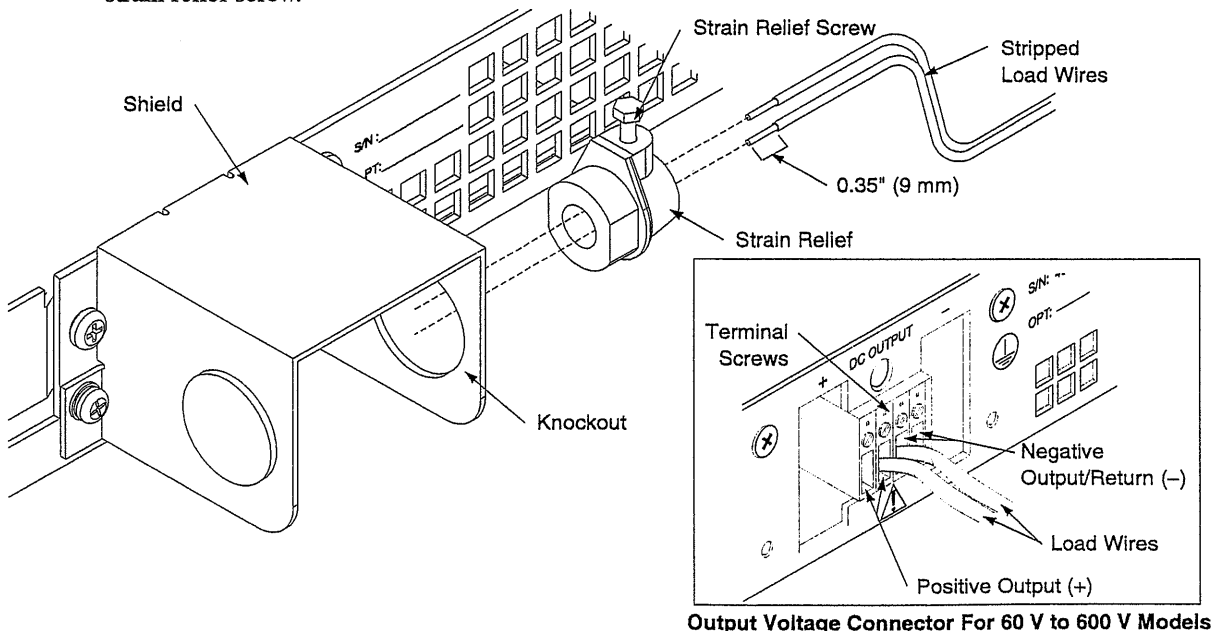

Figure 2.7-4 Output Voltage Connector with Shield
(For 60 V to 600 V models.)

2.7.3 Inductive Loads

To prevent damage to the power supply from inductive kickback, connect a diode across the output. The diode must be rated at greater than or equal to the supply's output voltage and have a current surge rating greater than or equal to the supply's output rating. Connect the cathode to the positive output and the anode to the negative output/return.

Where positive load transients such as back EMF from a motor may occur, connect a varistor across the output to protect the power supply. The breakdown voltage rating for the varistor must be approximately 10% higher than the rated supply output.

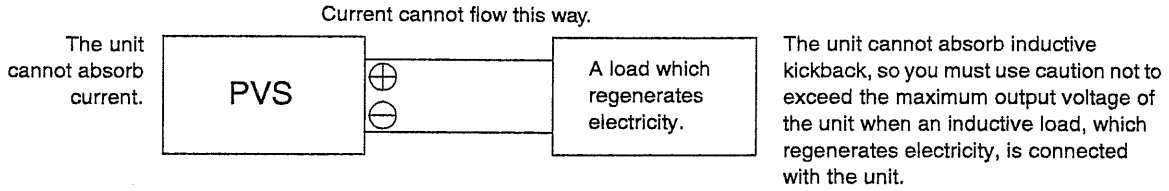
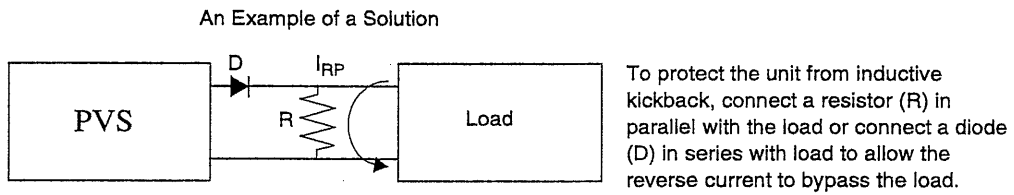

Figure 2.7-5 Inductive Load



$$R[\Omega] \leq \frac{E_O}{I_{RP}}$$

E_O : Power supply output voltage
 I_{RP} : Maximum kickback current

Figure 2.7-6 Inductive Load with Resistor

2.7.4 Connecting Single Loads

See Figure 2.7-7 and Figure 2.7-8 for recommended load and sensing connections for single loads. Local sense lines shown are default connections at the rear panel J10 sense connector.

You do not need remote sensing for basic operation of your supply. However, if you wish to correct any small drops in your load lines, then use the remote sensing feature.

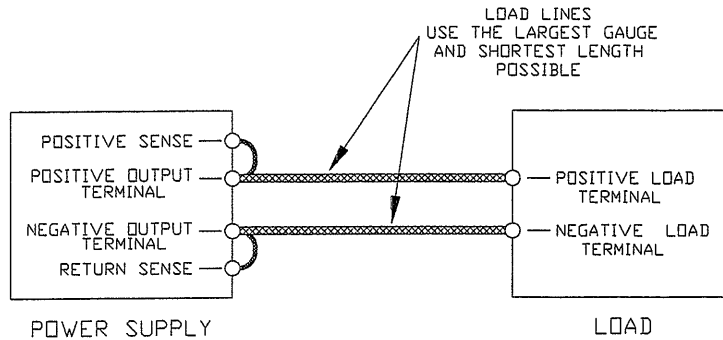

Figure 2.7-7 Single Load with Local Sensing (Default)

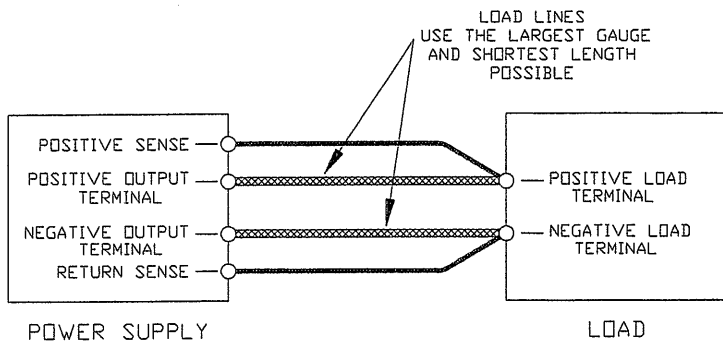

Figure 2.7-8 Single Load with Remote Sensing

2.7.5 Connecting Multiple Loads

Proper connection of distributed loads is an important aspect of power supply use. Two common methods of connection are the parallel power distribution method and the radial power distribution method.

Parallel Power Distribution

This distribution method involves connecting leads from the power supply to one load, from that load to the next load, and so on for each load in the system. This method results in the voltage at each load depending on the current drawn by the other loads and allows DC ground loops to develop. Except for low current applications, we do not recommend using this method.

2.7.5 Connecting Multiple Loads (continued)

Radial Power Distribution Method

To connect distributed loads, we recommend that you use radial power distribution. With this method, you connect power to each load individually from a single pair of terminals designated as the positive and negative distribution terminals. These terminals may be the power supply output terminals, the terminals of one of the loads, or a distinct set of terminals especially established for distribution use. Connect the sense leads to these terminals to compensate for losses and minimize the effect of one load upon another.

See Figure 2.7-9 and Figure 2.7-10 for recommended load and sensing connections for multiple loads. Local sense lines shown are default J10 sense connections. See Section 2.8 Local and Remote Sensing for more information about using remote sensing and grounding the sense line shield.

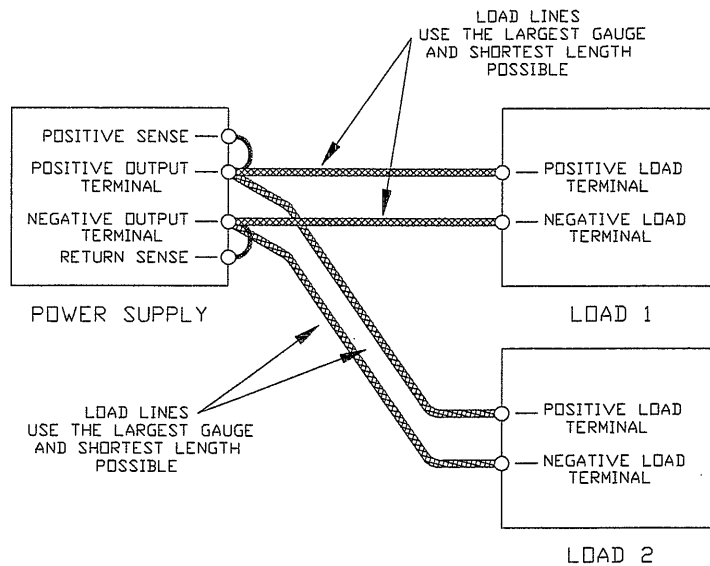

Figure 2.7-9 Multiple Loads with Local Sensing

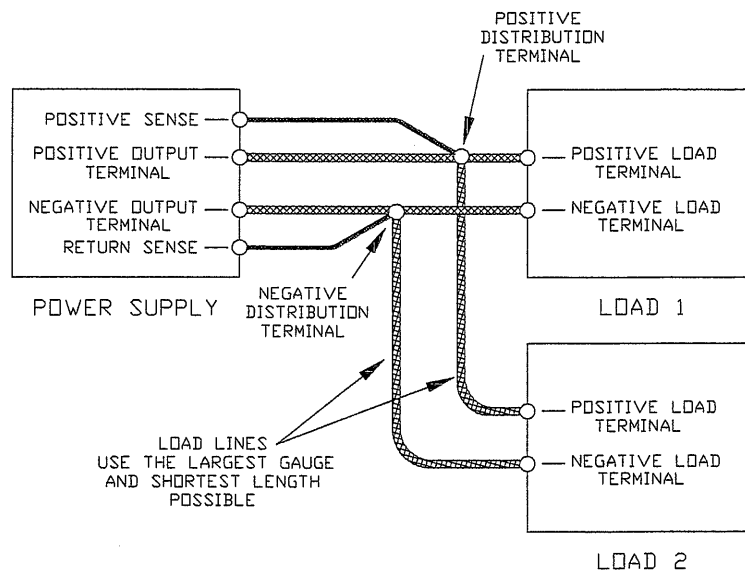
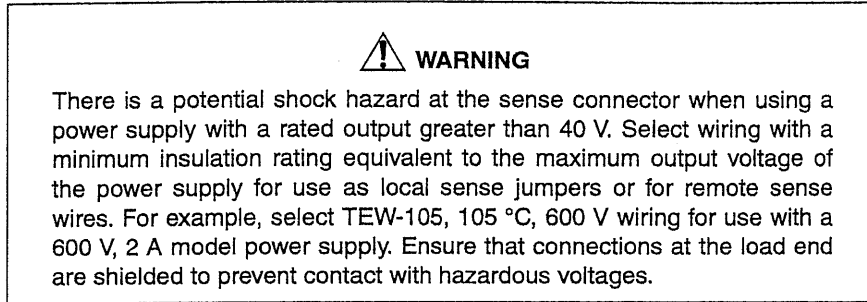

Figure 2.7-10 Multiple Loads with Remote Sensing

2.8 Local and Remote Sensing

Use connections at the rear panel J10 sense connector to configure the power supply for local or remote sensing of output voltage. See Figure 2.8-1 for a drawing of the sense connector.

2.8.1 Sense Wiring



For lowest noise performance, use shielded pair wiring of 16 to 24 AWG for remote sense lines. Strip wires 0.26" (6.5 mm), insert, and tighten the wire clamp.

2.8.2 Local Sensing

We ship the power supply with the rear panel J10 sense connector jumpered for local sensing of the output voltage. See Table 2.8-1 for the list of connector functions and a description of local sense connections. With local sensing, the output voltage is regulated at the output terminals (or bus bars). This method does not compensate for voltage losses in the load lines, so it is recommended only for low current applications or applications for which load regulation is not essential.

Note: When using local sense connections, use the largest practical load wire size to minimize the effects of line impedance on the regulation of the supply.

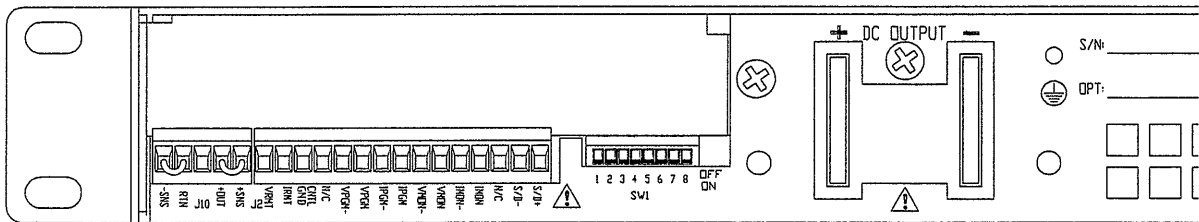

Figure 2.8-1 J10 Sense Connector
(Shown with local sense jumpers connected.)

Table 2.8-1 Rear Panel J10 Sense Connector Terminals and Functions

Terminal	Name	Function
J10-1	Return Sense (-SNS)	Remote negative sense connection. Default connection to terminal 2.
J10-2	Negative Output (Return or RTN)	Connected internally to negative bus bar.
J10-3	N/C	No connection.
J10-4	Positive Output (+OUT)	Connected internally to positive bus bar.
J10-5	Positive Sense (+SNS)	Remote positive sense connection. Default connection to terminal 4.

2.8.3 Using Remote Sensing

 **WARNING**

There is a potential shock hazard at the sense points when using a power supply with a rated output greater than 40 V. Ensure that connections at the load end are shielded to prevent contact with hazardous voltages.

CAUTION

Ground the sense line shield in one place only. Locations include: the power supply's return output connection at the load, the power supply's return output at its negative output terminal, or the power supply's chassis.

CAUTION

Do not use remote sensing with multiple supplies connected in series.

Use remote sensing during voltage mode operation to shift the power supply's regulation point from its default position at the rear panel output terminals to the load or distribution terminals by using a separate pair of wires to allow the control circuitry to monitor the load voltage. This allows the power supply to compensate for voltage losses in the load lines which will otherwise degrade the regulation of the supply. Line drop is subtracted from the total voltage available at the power supply output.

To connect remote sense lines:

1. Turn OFF the power supply.
2. Remove the local sense jumpers connecting J10 mating connector terminal 5 (positive sense) to terminal 4 (positive output) and terminal 1 (return sense) to terminal 2 (power supply return).
3. Connect the positive remote sense lead to J10 mating connector terminal 5 (positive sense) and the negative lead to terminal 1 (return sense). Ensure that the mating connector is plugged securely into the rear panel sense connector. Connect the other ends of the sense wires to the corresponding sense points at the load.
4. To prevent ground loops, ground the sense line shield, at one point only, to the power supply's return output connection at the load, to the power supply's return output at its negative output terminal, or to the power supply's chassis.
5. Turn the power supply ON.

- Notes:
1. If you operate the power supply with remote sense lines connected to the load and with either of the positive or negative load lines not connected, the power supply shutdown circuit will activate, causing the output voltage and current to fall to zero.
 2. If you operate the power supply without remote sense lines or local sense jumpers in place, the supply will continue to work, but supply regulation will be degraded and/or erratic, or, the OVP circuit may activate.

2.8.3 Using Remote Sensing (continued)

Figure 2.8-2 shows a sample setup for using remote sensing.

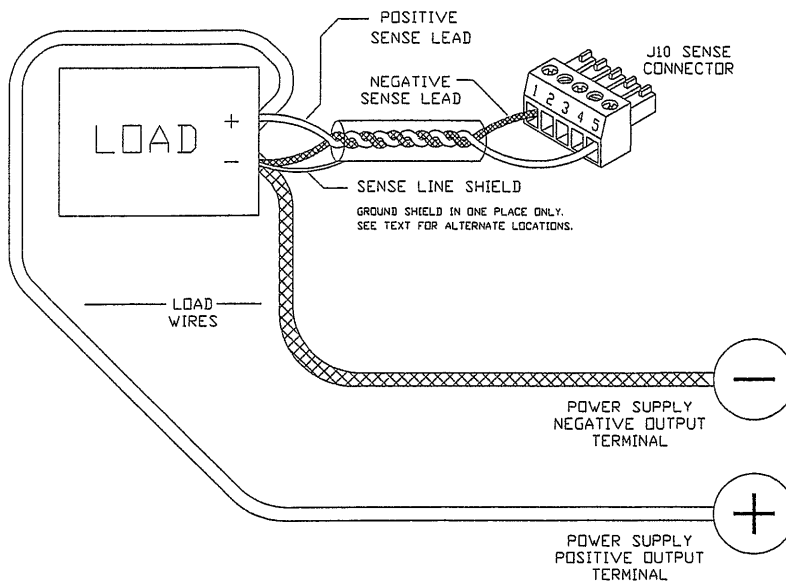

Figure 2.8-2 Connecting Remote Sense Lines

3. LOCAL OPERATION

3.1 Introduction

Once you have installed the power supply and have connected both the AC input power and the load as covered in Section 2. Installation, the power supply is ready to operate in local control mode (that is, operation at the unit's front panel).

- See Section 3.2 Standard Operation for a brief explanation of Constant Voltage and Constant Current Mode operation as controlled at the supply's front panel.
- See Section 3.3 to Section 3.6 for more about power supply functions such as over voltage protection, shutdown function, over heat protection, and using multiple supplies.
- See Section 3.7 for troubleshooting information for the operator.
- Turn to Section 4. Remote Operation for descriptions of remote programming options and remote monitoring of the power supply.

3.2 Standard Operation

This power supply has two basic operating modes: Constant Voltage Mode and Constant Current Mode, and two control modes: Local Control Mode (default setting) and Remote Programming Mode. Both operating modes are available regardless of which control mode is used.

3.2.1 Operating Modes and Automatic Crossover

Whether controlled by local or remote programming, the power supply has two basic operating modes: Constant Voltage Mode and Constant Current Mode. The mode in which the power supply operates at any given time depends on the combination of:

- output voltage setting V_{SET}
- output current limit setting I_{SET}
- resistance of the attached load R_L

See Figure 3.2-1 Operating Modes for a graphical representation of the relationships between these variables.

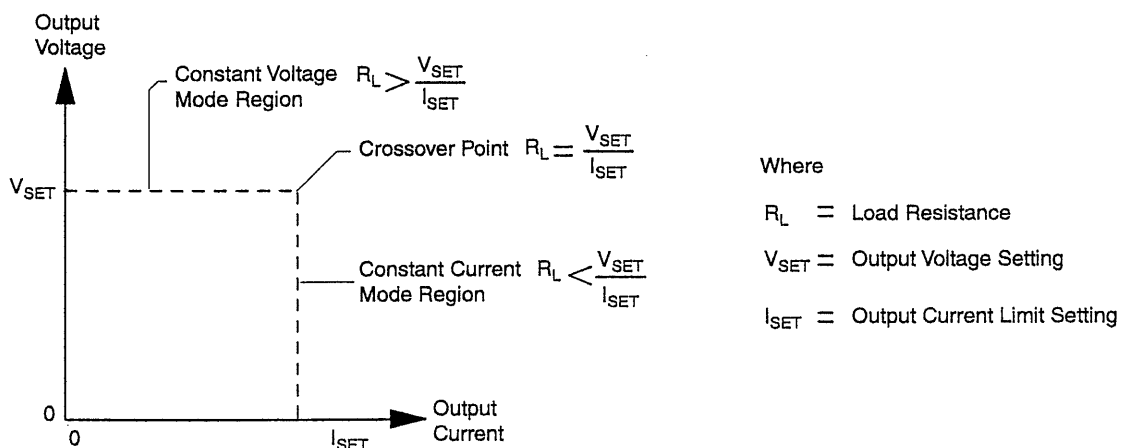

Figure 3.2-1 Operating Modes

3.2.1 Operating Modes and Automatic Crossover (continued)

Constant Voltage Mode Operation

The power supply will operate in constant voltage mode whenever the load current I_L is less than the current limit setting I_{SET} , or: $I_L < I_{SET}$ (Note: $I_L = V_{SET} / R_L$)

In constant voltage mode, the power supply maintains the output voltage at the selected value (V_{SET}) while the load current I_L varies with the load requirements.

Constant Current Mode Operation

The power supply will operate in constant current mode whenever the load resistance is low enough that the load current I_L is equal to the current limit setting I_{SET} (Note: $V_L = I_{SET} R_L$)

In constant current mode, the power supply maintains the output current at the selected value (I_{SET}) while the load voltage varies with the load requirements.

Automatic Mode Crossover

This feature allows the power supply to automatically switch operating modes in response to changing load requirements. If, for instance, the power supply was operating in Constant Voltage Mode ($I_L < I_{SET}$), and the load changed so that the load current (I_L) became equal to the current limit setting (I_{SET}), the power supply would automatically switch into Constant Current Mode and the output voltage would vary in response to changes in load current. If the additional load was subsequently removed so that the load current was again less than the current limit setting, the supply would automatically return to Constant Voltage Mode.

3.2.2 Shipped Configuration (Local Control Mode)

The factory ships units already configured for local control (front panel) operation. See Table 3.2-1 for a summary of this configuration.

Table 3.2-1 Shipped Configuration (Local Control Mode)

Local Control Configuration	Additional References
Use the front panel controls to adjust the output voltage and current limit settings. (Note: You can use the LCL (Return to Local) button only when you have a GPIB interface installed.)	See Section 3 for front panel operation. See Section 4. Remote Operation for remote analog programming procedure(s).
The supply's sense point is at the rear panel J10 sense connector terminals.	See Section 2.8 Local and Remote Sensing for how to change from local to remote sensing.
The over voltage protection (OVP) set point is adjusted at the front panel to approximately 110% of rated output voltage.	See Section 3.3 Using Over Voltage Protection (OVP) for the adjustment procedure.
The over heat shutdown function defaults to latch off (rear panel switch SW1-8 CLOSED). Automatic reset is also available.	See Section 3.6 Over Heat Protection (OHP) for more information about switch SW1-8 settings.

3.2.3 Setting Output Voltage and Current Limit

Install the power supply and connect the load as described in Section 2. Installation. Ensure that the power supply is set up for local control as described in Section 3.2.2. Then, set the output voltage and current limit at the front panel with the following procedure.

1. Turn both the voltage and current controls fully counter-clockwise.
2. Turn the AC power ON.
3. Press the STANDBY switch to its IN position to disable the power supply output. The red Shutdown (S/D) LED turns on.
4. Press and hold the V·I PRESET button to display the voltage and current control settings on the voltmeter and ammeter displays.
5. Adjust the voltage control to the desired voltage (the compliance voltage for applications using current mode operation).
6. Adjust the current control to the desired current limit setting.
7. Release the V·I PRESET button.
8. Press the STANDBY switch to its OUT position to apply power to the load. The S/D LED turns off.

Note: The control circuits have been designed to allow you to set output voltage and current up to 5% over the model-rated maximum values. The power supply will operate within these extended ranges, but we cannot guarantee full performance to specification.

3.3 Using Over Voltage Protection (OVP)

The OVP circuit protects the load in the event of a remote programming error, an incorrect voltage control adjustment, or a power supply failure. The protection circuit monitors the output voltage at the output of the power supply and will shut down the main power converter whenever a preset voltage limit is exceeded. Set the preset voltage limit (also called the set point or trip level) using the screwdriver-adjustable, front panel OVP potentiometer, or, by using the optional GPIB programming interface.

- Notes:
1. The default preset limit is approximately 110% of the rated output voltage.
 2. When using OVP with remote sensing lines connected, compensate for the voltage line drop across the output return line by measuring or calculating the line drop, then adding this value to the desired OVP setpoint.

3.3.1 Front Panel OVP Operation

In local control mode, check the OVP set point at any time by pressing the OVP PRESET switch. The OVP set point is the value displayed on the digital voltmeter.

To set the trip level from the front panel:

1. Disconnect any loads. Turn the power supply ON.
2. Adjust the power supply output voltage to any voltage lower than the desired trip level.
3. Press the front panel STANDBY (output shutdown) switch to its IN position. The red S/D LED turns on.
4. Press the OVP PRESET switch to see the OVP set point on the voltmeter display.
5. Holding down the OVP PRESET switch, turn the OVP SET potentiometer until the desired set point is reached. Release the OVP PRESET switch.
6. Press the STANDBY switch to its OUT position. The S/D LED turns off.
7. To check that the power supply shuts off at the desired set point, slowly increase the output voltage while monitoring the front panel voltmeter. The OVP LED on the front panel will light up when the OVP circuit activates.

3.3.2 Resetting the OVP Circuit

To reset the OVP circuit after it activates:

1. Reduce the power supply's output voltage setting to below the OVP set point.
2. Press the STANDBY switch IN. The red S/D LED on the front panel will light up. The OVP LED turns off.
3. Press the STANDBY switch again to return power to the load and resume normal operation.

OR

1. Reduce the power supply's output voltage setting to below the OVP set point.
2. Turn the power supply OFF using the AC power switch, wait until the front panel displays go out, then turn the power supply back ON again.

3.4 Using the Shutdown Function

Use the Shutdown function to disable or enable the supply's output so that you can make adjustments to either the load or the power supply without shutting off the power supply. Activate this function from the front panel at any time by using the STANDBY switch. You can also activate it via remote control through the rear panel J2 Programming and Monitoring connector, using a 2.5 to 15 V signal (or a transistor-transistor logic (TTL) compatible input). The input lines for the Shutdown circuit are optically isolated.

3.4.1 STANDBY Switch

The STANDBY switch is a press ON/press OFF switch located on the power supply's front panel. See the front panel diagram in Section 1.3. Push the switch to its IN position to activate the Shutdown circuit. The output voltage and current fall to zero and the red S/D (Shutdown) LED turns on. Push the switch once more to reset it to its OUT position and resume normal power supply operation.

3.4.2 Controlling the Shutdown Function via the J2 Connector

The shutdown circuit accepts a 2.5 to 15 V signal to disable or enable the power supply's output. Make connections for signals at connector J2, located on the unit's rear panel. Set rear panel switch SW1-7 to select signal logic. See Section 1.4 for more information about making J2 connector and SW1 switch changes.

To activate the shutdown function:

1. Turn OFF the power supply.
2. Connect the signal source to J2 connector terminal 15 (Shutdown Input/positive) and terminal 14 (Shutdown Return).
3. Set switch SW1-7 to select the desired circuit logic as set out in Table 3.4-1.
4. Turn on the power supply. The power supply will operate as described in the **Supply Output** column in Table 3.4-1, according to the logic you select and the level of the input signal. The S/D (Shutdown) LED on the front panel turns on when the Shutdown circuit is activated.

Table 3.4-1 Switch Settings for Shutdown Circuit Logic

Switch SW1-7 Setting	Source Signal	Signal Level	Supply Output	S/D LED
OFF (OPEN) (Active low, default)	2-15 V	HIGH	OFF	ON
	0-0.4 V	LOW	ON	OFF
ON (CLOSED) (Active high)	2-15 V	HIGH	ON	OFF
	0-0.4 V	LOW	OFF	ON

- Notes:
1. If switch SW1-7 is ON but there is no signal applied, the S/D LED turns on and the power supply will not provide an output until the HIGH signal level is applied.
 2. Any of the eight switches on SW1 is OFF (OPEN) when it has been flipped up to break contact, ON (CLOSED) when flipped down to close contact.

3.5 Using Multiple Supplies

 **WARNING**

There is a potential shock hazard at the load when using a power supply with a rated *or combined* output greater than 40 V. To protect personnel against accidental contact with hazardous voltages created by series connection, ensure that the load, including connections, has no live parts which are accessible. Also ensure that the insulation rating of the load wiring and circuitry is greater than or equal to the maximum *or combined* output voltage of the power supply.

CAUTION

Do not connect power supplies from different manufacturers in parallel or in series.

CAUTION

The remote programming inputs are internally referenced to the supply's negative output. Do not connect remote programming ground lines (J2 terminals 3, 5, and 7) to the supply's positive output.

You can operate power supplies of the SAME MODEL with outputs in series or in parallel to obtain increased load voltage or increased current. Split supply operation gives you two positive outputs or a positive and a negative output.

3.5.1 Configuring Multiple Supplies for Series Operation

CAUTION

Do not use remote sensing during series operation.

CAUTION

The maximum allowable sum of the output voltages is 600 Vdc.

Use series operation to obtain a single higher voltage output using two or more supplies. Connect the negative (–) output terminal of one supply to the positive (+) output terminal of the next supply as shown in Figure 3.5-1. The total voltage available is the sum of the maximum voltages of each supply (add voltmeter readings, to a maximum of 600 V). The maximum allowable current for a series string of power supplies is the output current of a single supply in the string.

3.5.1 Configuring Multiple Supplies for Series Operation (continued)

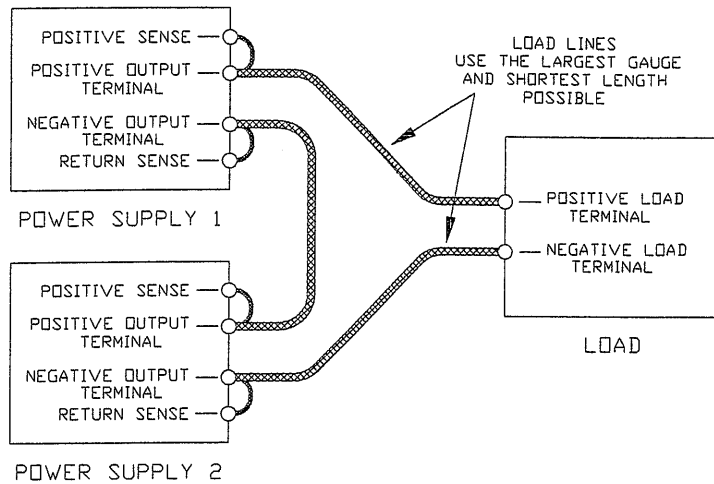

Figure 3.5-1 Series Operation of Multiple Supplies
(Local sense lines shown are default J10 connections.)

3.5.2 Configuring Multiple Supplies for Parallel Operation

Use parallel operation to obtain a higher current through a single output using two or more supplies. Set all of the OVP setpoints to maximum. (See Section 3.3 Using Over Voltage Protection (OVP).) Set all of the outputs to the same voltage before connecting the positive (+) output terminals and negative (-) output terminals in parallel. See Figure 3.5-2. The total current available is the sum of the maximum currents of each supply.

When operating multiple supplies in parallel, the operating mode of each supply depends on the load current being drawn. For example, with two 40 V, 30 A power supplies operating in parallel with a 50 A load, one supply operates in constant current mode supplying 30 A and the other supply operates in voltage mode supplying the remaining 20 A. The level of current sharing between units depends on how accurately the output voltages are matched.

Note: If you do not fix the OVP setpoints at maximum, the OVP circuit may trip on one unit, reducing the current available to the load.

Sensing for Parallel Operation

Use default local sensing to enhance power sharing between units, as the impedance of the load lines will tend to correct for current imbalance. If you use remote sensing at the load for better voltage regulation, one supply always operates in current limit mode and supplies most of the power.

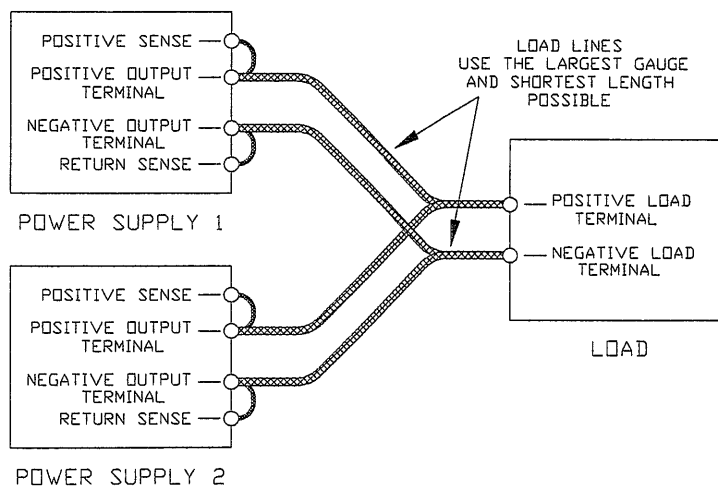

Figure 3.5-2 Parallel Operation of Multiple Supplies
(Local sense lines shown are default J10 connections.)

3.5.3 Configuring Multiple Supplies for Split Supply Operation

Split supply operation uses two power supplies to obtain two positive voltages with a common ground, or to obtain a positive-negative supply.

Two Positive Voltages

To obtain two positive voltages, connect the negative output terminals of both supplies together in a common connection. The positive output terminals will provide the required voltages with respect to the common connection. See Figure 3.5-3.

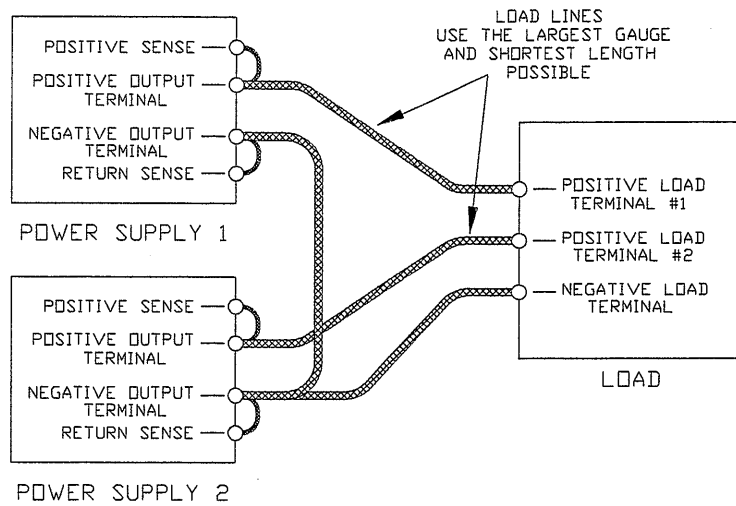

Figure 3.5-3 Split Supply Operation of Multiple Supplies (Two Positive Voltages)
 (Local sense lines shown are default J10 connections.)

3.5.3 Configuring Multiple Supplies for Split Supply Operation (continued)

Positive-negative Supply

CAUTION

To prevent possible damage to the supply, do not connect the remote program return line of the negative supply to the common connection.

To obtain a positive-negative supply, connect the negative output terminal of one supply to the positive output terminal of the second supply. The positive output terminal of the first supply then provides a positive voltage relative to the common connection while the negative output terminal of the second supply provides a negative voltage. You can set the current limits independently. The maximum current available in split supply operation is equal to the rated output of the supplies. For example, 30 A for two 40 V, 30 A models. See Figure 3.5-4.

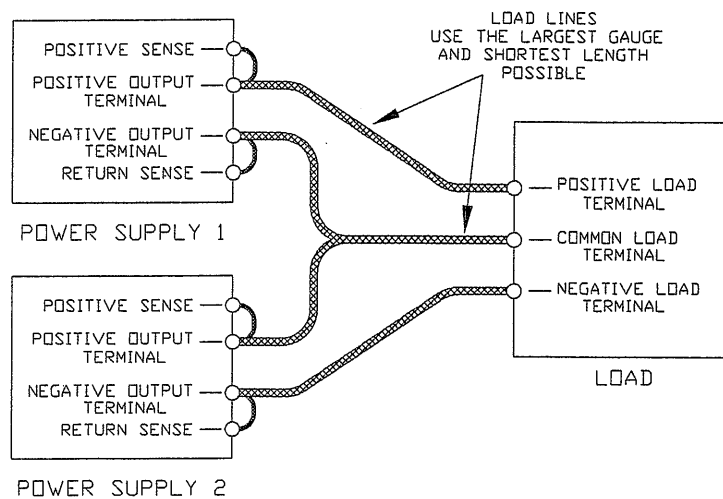

Figure 3.5-4 Split-Supply Operation of Multiple Supplies (Positive-negative Supply)
(Local sense lines shown are default J10 connections.)

3.6 Over Heat Protection (OHP)

The OHP function allows you to select how the power supply recovers from an over heat shutdown using the rear panel switch SW1-8. See Table 3.6-1 for the switch settings and selections. See Section 1.4 for more information about the switch. The OHP shutdown circuit activates before the internal components can exceed their safe internal operating temperatures. When an OHP shutdown occurs, the front panel OHP LED turns on.

Table 3.6-1 Switch Settings for Over Heat Recovery Options

Switch SW1-8	OHP Shutdown Selection	Description
OFF (OPEN)	Auto Reset	The supply recovers to normal operation when the over heat condition no longer exists.
ON (CLOSED)	Latch OFF (Default)	After an over heat shutdown, the supply stays off until you turn the AC power switch OFF, then you turn the power supply ON to continue use.

3.7 User Diagnostics

If your power supply is not performing as described in this operating manual, run through the procedures and checks in this section. These procedures are confined to operator-level functions only and do not require cover-off servicing.

3.7.1 Emergency Shutdown

In an emergency, carry out both of these steps:

1. Shut the power supply off immediately.
2. Disconnect the power supply from the load.

3.7.2 Unusual or Erratic Operation

If the power supply displays any unusual or erratic operation, follow these steps:

1. Shut the power supply off immediately.
2. Disconnect the power supply from the load.
3. Test the power supply with no load, running the tests in Section 2.6 Functional Tests.
4. If the tests show that the power supply is functioning normally, check all load, programming, and monitoring connections and circuits.
5. Check the AC input for correct voltage and frequency.

If the problem is not solved after following this procedure, or if the unit fails to operate correctly upon retesting, call our dealer or branch office.

Turn to the next page for more information about troubleshooting for operators.

3.7.3 Troubleshooting for Operators

Use the checks in Table 3.7-1 to ensure that the power supply is configured and connected for normal operation.

Abbreviated References Used in Table

ACF	AC Fail
OHP	over heat protection
OVP	over voltage protection
RMT	remote mode
S/D	shutdown

Table 3.7-1 User Diagnostics

Symptom	Check	Further Checks and Corrections
No output and the display is blank.	Is input voltage within specified range?	Connect to appropriate voltage source. See Section 2.5.
	Power switch ON?	Turn on power.
	Internal circuit?	Call our dealer or branch office.
No output but the display turns on.	OVP LED turned on?	See Section 3.3.
	Front panel S/D LED turned on?	See Section 3.4.
	OHP LED turned on?	See Section 3.6.
	Current limit set to zero?	See Section 3.2.
	Voltage control set to zero?	See Section 3.2.
	RMT LED turned on?	If using remote analog control, check your analog programming source (Section 4). If not, refer to your GPIB interface manual.
	Is front panel ACF LED turned on?	Connect unit to AC supply in specified range. See Section 2.5.
Output not adjustable.	Internal circuit.	Call our dealer or branch office.
	Is unit in current limit mode? (Red Current Mode LED turned on.)	Turn current knob clockwise to increase current limit. Reduce load if current is at maximum. See Section 3.2.
	Is unit in remote mode? (Green RMT LED turned on.)	If using remote analog control, check your analog programming source (Section 4). If not, refer to your GPIB interface manual.
Output voltage fluctuating or regulation poor.	Is unit at maximum voltage or current limit?	Reduce load for lower voltage or current requirement.
	Is unit at current limit?	Increase current limit setting or reduce load. See Section 3.2.
	Is input voltage within specified range?	Connect to appropriate AC voltage source. See Section 2.5.
	Are sense lines connected?	See Section 2.7 Load Connection and Section 2.8 Local and Remote Sensing.
	Is unit under remote analog control?	Ensure program source is stable.
Output oscillating.	Internal circuit.	Call our dealer or branch office.

4. REMOTE OPERATION

4.1 Introduction

The rear panel switches and connector on the power supply allow you to program the supply with an analog device or to output readback signals. This section covers the following topics.

- See Section 4.2 for information about remote analog programming of output voltage and current limit with 0-5 V and 0-10 V voltage sources and 0-5 k and 0-10 k resistances.
- See Section 4.3 for connector and switch settings for using calibrated readback signals for output voltage and output current with 0-10 V.

Remote Digital Programming

You can operate the power supply from a computer if you have had the GPIB Interface card installed as an option. Refer to the separate interface manual for all setup and operation instructions.

4.2 Remote Analog Programming of Output Voltage and Current Limit

Remote analog programming allows control of the power supply's output voltage and/or current limit to shift from local operation at the front panel voltage and current controls to external analog sources. As you vary the external programming source, the power supply's output varies proportionally over its output range.

Using remote analog programming requires that you reset switch SW1 and make connections to the J2 connector on the power supply's rear panel. See Section 1.4 Rear Panel Connectors and Switch.

4.2.1 Remote Programming Options

See Table 4.2-1 for a summary of the options available to you for programming output voltage and current limit using an analog source.

Table 4.2-1 Remote Programming Options

Control of...	Programming Scales ¹
Output Voltage and/or	0-5 V and 0-10 V voltage sources
Current Limit	0-5 k and 0-10 k resistances

1. These scales may be used in any combination.

4.2.2 Remote Analog Programming Procedure

CAUTION

To maintain the isolation of the power supply output and prevent ground loops, use an isolated (ungrounded) programming source when operating the power supply via remote analog control at the J2 connector.

CAUTION

The remote programming inputs are internally referenced to the supply's negative output. Do not connect control ground (J2 terminals 3, 5, or 7) to the supply's positive output.

1. Turn the power supply OFF.
2. Set switches SW1-1, SW1-2, SW1-3, and SW1-4 according to the programming sources that you are using, as indicated in Table 4.2-2. See Notes at the end of this procedure for more information about switch settings.
3. Install any required J2 connector jumpers as indicated in Table 4.2-2.
4. Connect the programming source(s) to the mating J2 connector as shown in Figure 4.2-1 and observe the correct polarity for voltage sources. Ensure that the mating connector is plugged securely into the rear panel connector.
5. Set the programming sources to the desired levels and turn the power supply ON. The RMT LED turns on. Adjust the external programming source to change the power supply's output.

- Notes:
1. Any of the eight switches on SW1 is OFF (OPEN) when it has been flipped up to break contact, ON (CLOSED) when flipped down to close contact.
 2. Switches SW1-5, SW1-6, SW1-7, and SW1-8 are not required for remote programming. They remain at the settings you have selected for your application.
 3. Switches SW-1 to SW-4 can be set to their defaults (1 and 2 open, 3 and 4 closed) unless otherwise specified in Table 4.2-2. See Section 1.4.1 Rear Panel SW1 Switch for default settings.
 4. The control circuits have been designed to allow you to set output voltage and current up to 5% over the model-rated maximum values. The power supply will operate within these extended ranges, but we cannot guarantee full performance to specification.

4.2.2 Remote Analog Programming Procedure (continued)

Table 4.2-2 Power Supply Settings for Different Programming Sources

Output Voltage Programming Source	Output Current Limit Programming Source				
	0-5 Vdc	0-10 Vdc	0-5 k Resistor	0-10 k Resistor	None (Front Panel Control)
0-5 Vdc	SW1: set 3 and 4 open. J2: jumper 1 to 3 and 2 to 3.	SW1: set 3 open. J2: jumper 1 to 3 and 2 to 3.	SW1: set 2 closed, 3 and 4 open. J2: jumper 1 to 3 and 2 to 3.	SW1: set 2 closed, 3 open. J2: jumper 1 to 3 and 2 to 3.	SW1: set 3 open. J2: jumper 1 to 3.
0-10 Vdc	SW1: set 4 open. J2: jumper 1 to 3 and 2 to 3.	SW1: default settings. J2: jumper 1 to 3 and 2 to 3.	SW1: set 2 closed, 4 open. J2: jumper 1 to 3 and 2 to 3.	SW1: set 2 closed. J2: jumper 1 to 3 and 2 to 3.	SW1: default settings. J2: jumper 1 to 3.
0-5 k Resistor	SW1: set 1 closed, 3 and 4 open. J2: jumper 1 to 3 and 2 to 3.	SW1: set 1 closed, 3 open. J2: jumper 1 to 3 and 2 to 3.	SW1: set 1 and 2 closed, 3 and 4 open. J2: jumper 1 to 3 and 2 to 3.	SW1: set 1 and 2 closed, 3 open. J2: jumper 1 to 3 and 2 to 3.	SW1: set 3 open, 1 closed. J2: jumper 1 to 3.
0-10 k Resistor	SW1: set 1 closed, 4 open. J2: jumper 1 to 3 and 2 to 3.	SW1: set 1 closed. J2: jumper 1 to 3 and 2 to 3.	SW1: set 1 and 2 closed, 4 open. J2: jumper 1 to 3 and 2 to 3.	SW1: set 1 and 2 closed. J2: jumper 1 to 3 and 2 to 3.	SW1: set 1 closed. J2: jumper 1 to 3.
None (Front Panel Control)	SW1: set 4 open. J2: jumper 2 to 3.	SW1: default settings. J2: jumper 2 to 3.	SW1: set 2 closed, 4 open. J2: jumper 2 to 3.	SW1: set 2 closed. J2: jumper 2 to 3.	SW1: default settings. J2: no jumper.

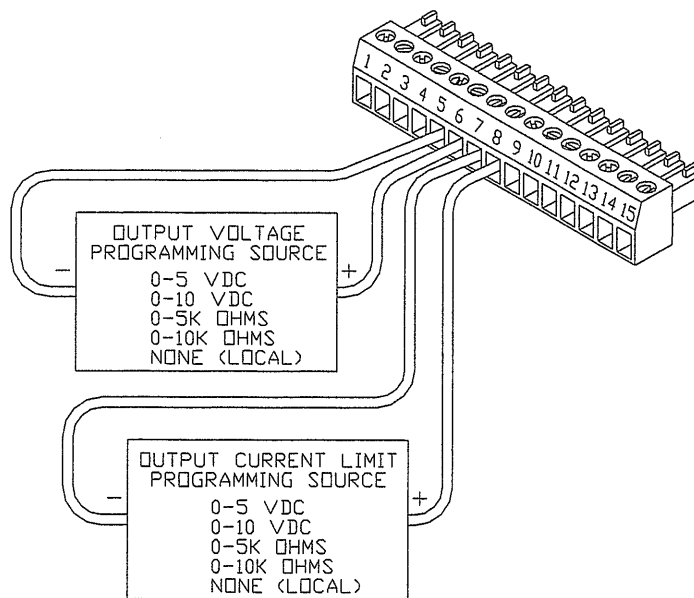

Figure 4.2-1 Connecting Programming Sources to J2 Connector

4.3 Remote Monitoring of Output Voltage and Current

4.3.1 Readback Signals

The J2 connector on the rear panel provides access to calibrated readback signals for remote monitoring of the output voltage and current. Rear panel switches SW1-5 and SW1-6 allow you to monitor the output with a 0 to 10 Vdc signal. The readback signal represents 0 to 100% of the power supply's output.

See Table 4.3-1 for the required J2 connections and switch settings for remote monitoring of readback signals. Use shielded pair wiring (20 to 24 AWG) and ground the shield to J10 sense connector terminal 1 (return sense) or to the chassis.

Table 4.3-1 Power Supply Settings for Remote Monitoring of Readback Signals

Readback Signal	J2 Connection Signal (+)	J2 Connection Return (-)	Switch SW1 Setting
Output Voltage (Not available)	J2-10	J2-9	SW1-5 OFF (OPEN)
Output Voltage (0-10 Vdc)	J2-10	J2-9	SW1-5 ON (CLOSED)
Output Current (Not available)	J2-12	J2-11	SW1-6 OFF (OPEN)
Output Current (0-10 Vdc)	J2-12	J2-11	SW1-6 ON (CLOSED)

APPENDIX A. PROCEDURES FOR REMOTE PROGRAMMING

A.1 Remote Programming with External Resistance¹

A.1.1 Remote Output Voltage Control with External Resistance

To use remote output voltage programming via an external resistor:

1. Set switch SW1-1 to ON (CLOSED). This setting enables resistive programming of output voltage.
2. Set switch SW1-3 to ON (CLOSED). This position sets the output voltage programming source at 0-10 k Ω (If you set switch SW1-3 to OFF (OPEN), the output voltage programming source will be set at 0-5 k Ω)
3. Jumper terminals J2-1 and J2-3 at the J2 connector. This connection selects remote output voltage programming. Use 16-24 AWG wire for the jumpers.
4. Connect an external resistor between terminals J2-5 and J2-6 at the J2 connector.

CAUTION

Choose a metal film or wire-wound resistor with good stability, a low temperature coefficient, and a power rating of at least 0.5 watts.

5. To avoid noise issues, use shielded pair wiring when making connections from the J2 connector to the external resistor.
6. If you disconnect the external resistor, the power supply will operate at its highest voltage setting. To protect your power supply, we recommend that you set an appropriate value for OVP.

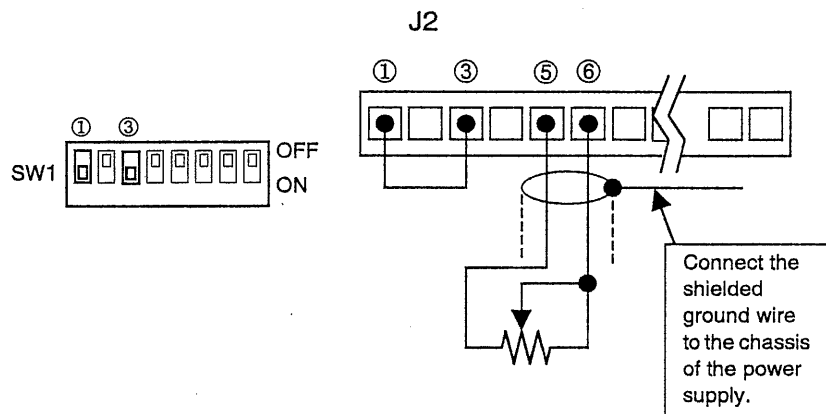

Figure A-1 Remote Output Voltage Control with External Resistance

1. Recommended remote control distance: within 5 m.

A.1.2 Remote Output Current Control With External Resistance

To use remote output current programming via an external resistor:

1. Set switch SW1-2 to ON (CLOSED). This setting enables resistive programming of output current.
2. Set switch SW1-4 to ON (CLOSED). This position sets the output current limit programming source at 0-10 kΩ (If you set switch SW1-4 to OFF (OPEN), the output current limit programming source will be set at 0-5 kΩ)
3. Jumper terminals J2-2 and J2-3 at the J2 connector. This connection selects remote output current programming. Use 16-24 AWG wire for the jumpers.
4. Connect an external resistor between terminals J2-7 and J2-8 at the J2 connector.

CAUTION

Choose a metal film or wire-wound resistor with good stability, a low temperature coefficient, and a power rating of at least 0.5 watts.

5. To avoid noise problems, use shielded pair wiring when making connections from the J2 connector to the external resistor.

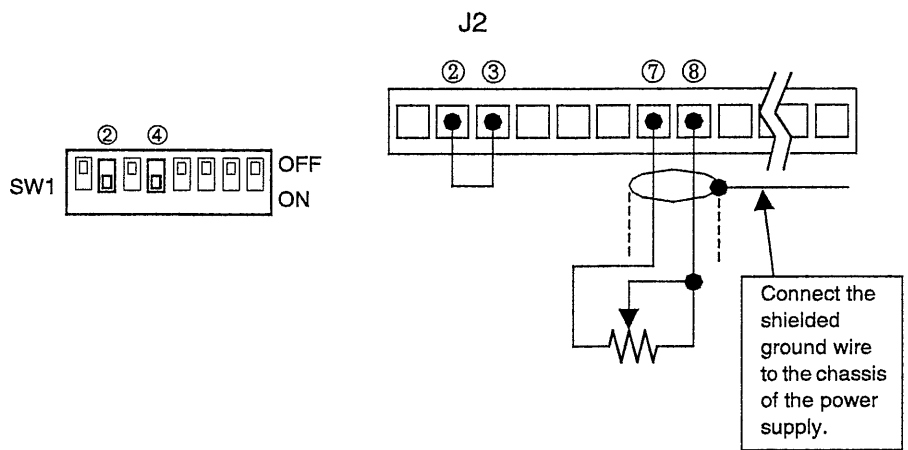

Figure A-2 Remote Output Current Control With External Resistance

A.2 Remote Programming with External Voltage Sources ¹

A.2.1 Remote Output Voltage Control with External Voltage Sources

To use remote output voltage programming via an external voltage source:

1. Set switch SW1-1 to OFF (OPEN). This setting enables voltage source programming.
2. Set switch SW1-3 to ON (CLOSED) position. This position sets the output voltage programming source at 0-10 V. (If you set switch SW1-3 to OFF (OPEN), the output voltage programming source will be set at 0-5 V.)
3. Jumper terminals J2-1 and J2-3 at the J2 connector. This connection selects remote output voltage programming. Use 16-24 AWG wire for the jumpers.
4. Connect the external voltage source between terminals J2-5 and J2-6 at the J2 connector. Input impedance should be approximately 100k Ω .

CAUTION

Use an isolated external voltage source when programming with external voltage sources. If an external voltage source is connected to the load circuit and/or chassis ground, it may damage the control circuit of your power supply.

5. To avoid noise issues, use shielded pair wiring when making connections from the J2 connector to an external voltage source.

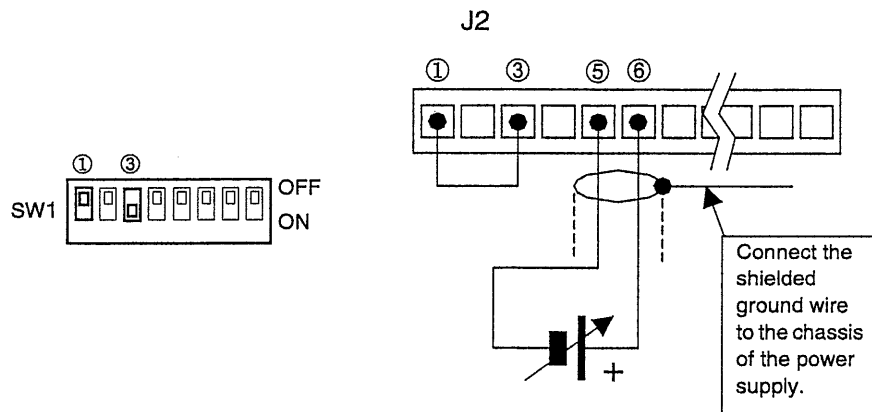

Figure A-3 Remote Output Voltage Control with External Voltage Sources

1. Recommended remote control distance: within 10 m.

A.2.2 Remote Output Current Control With External Voltage Sources

To use remote output current programming via an external voltage source:

1. Set switch SW1-2 to OFF (OPEN). This setting enables voltage source programming.
2. Set switch SW1-4 to ON (CLOSED). This selection sets the output current limit programming source at 0-10 V. (If you set switch SW1-4 to OFF (OPEN), the output current limit programming source will be set at 0-5 V.)
3. Jumper terminals J2-2 and J2-3 at the J2 connector. This setting enable remote output current limit programming. Use 16-24 AWG wire for the jumpers.
4. Connect the external voltage source between terminals J2-7 and J2-8 at the J2 connector. Input impedance should be approximately 100k Ω .

CAUTION

Use an isolated external voltage source when programming with external voltage sources. If an external voltage source is connected to the load circuit and/or chassis ground, it may damage the control circuit of your power supply.

5. To avoid noise issues, use shielded pair wiring when making connections from the J2 connector to an external voltage source.

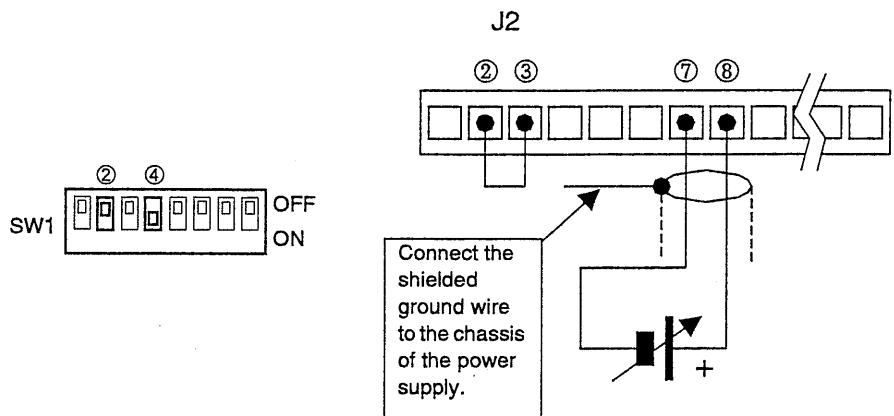

Figure A-4 Remote Output Current Control With External Voltage Sources